

**TATA INSTITUTE OF FUNDAMENTAL RESEARCH**  
**Survey No.36/P, Gopanpally Village, Serilingampally Mandal**  
**Ranga Reddy District, Hyderabad-500046, Telangana**

Telephone : +91-40-20203010  
Website : [www.tifrh.res.in](http://www.tifrh.res.in)

Date:01-09-2020  
Email: [rajasekharr@tifrh.res.in](mailto:rajasekharr@tifrh.res.in)

**PUBLIC TENDER**

**(TWO PART TENDER)** for the following Works:

**Annual Maintenance Contract for deploying Manpower for Plumbing/Carpentry Works/Operation & Maintenance of STP at TIFR, Survey No. 36/P, Gopanpally (Village), Serilingampally (Mandal), RR Dist., Hyderabad-500046.**

<b>Tender No.</b>	<b>TIFR/PD/CF20-19/200276</b>
<b>Type of Tender</b>	<b>Two Part Tender (Part-I: Technical Bid and Part-II: Financial Bid)</b>
<b>Estimated Cost</b>	<b>Rs. 20,30,000/-</b>
<b>Cost of EMD</b>	<b>Rs.40,600/-(Demand Draft to be drawn in favour of “TIFR Centre for Interdisciplinary Sciences”, Payable at Hyderabad (To be enclosed with the Technical Bid Part –I))</b>
<b>Pre-Bid Meeting Date, Time and Place</b>	<b>03.09.2020 at 15:00 hrs</b>
<b>Last Date for Submission of Tender</b>	<b>09.09.2020 by 13:00 hrs</b>
<b>Date of Opening Bids(Only Part-I: Technical Bid)</b>	<b>09.09.2020 at 15:00 hrs</b>
<b>Tender Fee</b>	<b>Rs. 500/-(Demand Draft to be drawn in favour of “TIFR Centre for Interdisciplinary Sciences”, Payable at Hyderabad (To be enclosed with the Technical Bid Part –I))</b>

- In case the Part“T” and Part“IP” bids are not sealed in separate envelopes the tender will be rejected.
- The technical bid should not contain any indication of the price.
- The Technical Bid received without payment of tender fees and EMD shall be summarily rejected.

**TATA INSTITUTE OF FUNDAMENTAL RESEARCH**  
**Survey No.36/P, Gopanpally Village, Serilingampally Mandal**  
**Ranga Reddy District, Hyderabad-500046, Telangana**

---

- Contacts: Head-Technical Services Tel: 040-20203010 for commercial and Mr. Ashis Panigrahi. Tel: 040-20203004 for technical clarifications.

Sealed tenders are invited for AMC for the aforesaid works from contractors having similar work experience in reputed Research Institutions, Universities, Central Government/Public Sector Undertaking, Private Laboratories, Multinational Companies, etc. Interested contractors and who are satisfying prequalification criteria stipulated by TIFR-Hyderabad shall only submit their bids. For further details and any clarification on the tender you may please contact Head-Technical Services, Survey No.36/P, Gopanpally Village, Serilingampally Mandal, RangaReddy District, Hyderabad-500046

Last date for submission of the tender is 09.09.2020 by 13:00 hrs.

  
Rajasekhar R  
Head Technical Services

**TENDER DOCUMENT**

**Annual Maintenance Contract for deploying Manpower for Plumbing/Carpentry Works/Operation & Maintenance of STP at TIFR, Survey No. 36/P, Gopanpally (Village), Serilingampally (Mandal), RR Dist., Hyderabad-500046.**

NAME OF THE TENDERER: -----

ADDRESS: -----

-----

-----

-----

Last date of submission of the tender: On or before 09.09.2020 by 13:00 hrs.

**PART – I**

**Annual Maintenance Contract for deploying Manpower for Plumbing/Carpentry Works/Operation & Maintenance of STP at TIFR, Survey No. 36/P, Gopanpally (Village), Serilingampally( Mandal), RR Dist., Hyderabad-500046.**

**TECHNICAL BID**

**Tender Notice : TIFR/PD/CF20-19/200276**

**Estimated Cost : Rs. 20,30,000/-**

**EMD : Rs.40,600/- (Rupees Forty Thousand Six Hundred Only)**

**Validity : One Hundred and twenty (120) days after opening of Part-II, Financial Bid**

**Annual Maintenance Contract for deploying Manpower for Plumbing/Carpentry Works/Operation & Maintenance of STP at TIFR, Survey No. 36/P, Gopanpally (Village), Serilingampally(Mandal), RR Dist, Hyderabad-500046.**

**INDEX**

<b>Sr. No.</b>	<b>Contents</b>	<b>Page No.</b>
1	Notice Inviting Tender	6-9
2	Form of Tender (Annexure-I)	10
3	Application Form (Annexure-II)	11-15
4	Scope of Work (Annexure-III)	16-27
5	Instruction for Tenderers (Annexure-IV)	28-29
6	General Terms & Conditions (Annexure-V)	30-36
7	Special Conditions of Contract	37-38
8	Appendix to Form of Tender	39
9	Price Bid (PART-II) <b><u>(Should be enclosed in a separate envelope)</u></b>	40-43

**NOTICE INVITING TENDER**

**Annual Maintenance Contract for deploying Manpower for Plumbing/Carpentry Works/Operation & Maintenance of STP at TIFR, Survey No. 36/P, Gopanpally (Village), Serilingampally(Mandal), RR Dist, Hyderabad-500046.**

Applications are invited in the prescribed format Annual Maintenance Contract for deploying Manpower for Plumbing/Carpentry Works/Operation & Maintenance of STP at TIFR, Survey No. 36/P, Gopanpally (Village), Serilingampally(Mandal), RR Dist, Hyderabad-500046.

Details regarding tender are given as below:

**I. Eligibility Criteria:**

Tenderers who fulfill the following requirements shall be eligible to apply.

1. The tenderer should have satisfactorily carried out AMC for deploying manpower for STP/Plumbing/Carpentry basis on all days works for Premier Research Institutes, Universities, Public Sector Undertakings(PSUs) institutes, Multinational Companies(MNCs) etc. for following contract value/s during last 7 (Seven) years as on previous month ending to the date of issue of application:
  - i. One (1) similar work of AMC contract with minimum value of around Rs.16.24 lakh per annum
  - OR
  - ii. Two (2) similar works each of AMC contract with minimum value of around Rs.12.18 lakh per annum
  - OR
  - iii. Three (3) similar works each of AMC contract with minimum value of around Rs 8.12 lakh per annum.
2. Average annual turnover of the tenderer during the last 3 (three) years ending March 31, 2020 shall be at least Rs. 8.12 lakh.
3. The tenderer should have office based in Hyderabad with technically qualified staff to render the said services and with necessary Plumbing/Carpentry/STP and labour license registration (copy of valid license to be submitted to TIFR, Hyderabad).

**Note:** The details furnished shall be for the maintenance jobs & not for the installation works. The contractor must have experience in operation & maintenance of Sewage Treatment Plant(STP).The vendors submitting the credential of installation works shall not be eligible for prequalification.

**II. Credentials:**

The tenderer should also furnish the following information in Cover-1 (Prequalification Bid):

1. Information desired regarding eligibility criteria as per format given Annexure-I.
2. Company profile & Bank's NEFT details of the company/contractor/firm etc.

**TATA INSTITUTE OF FUNDAMENTAL RESEARCH**  
**Survey No.36/P, Gopanpally Village, Serilingampally Mandal**  
**Ranga Reddy District, Hyderabad-500046, Telangana**

---

3. Name & address of the clients for whom the jobs were executed as per format given in Annexure-II.
4. Copies of the Certificates from the clients for satisfactory performance.
5. Desirous tenderers may either download the applications from website (**Tender reference No. TIFR/PD/CF20-19/200276**) or collect the tender document from TIFR-Hyderabad, HEAD-Technical Services at Survey No. 36/P, Gopanpally(Village), Serilingampally (Mandal), RR Dist, Hyderabad-500046 and submit completed applications along with the required documents.

**III. Earnest Money Deposit:**

Earnest Money Deposit (EMD) of Rs. 40,600/- (Rupees Forty Thousand Six Hundred Only) shall be submitted in form of Demand Draft from Scheduled Bank drawn in favour of “TIFR Centre for Interdisciplinary Sciences”, Hyderabad. The EMD so obtained shall be submitted in Cover-1 of the tender.

**IV. Instruction for Filling & Submission of Tender:**

1. The tender amount is to be inserted in words as well as in figure in the space provided, in case of any discrepancies in the prices written in words and figures, the prices written in the words shall be considered to be correct.
2. Rates quoted in the tender shall be inclusive of labour, GST, transportation, insurance for carrying out any work etc (except the cost of spares required for replacement/maintenance of the plumbing/sanitary/carpentry items which should be borne by TIFR-Hyderabad). The quoted rates should be with consideration of latest Minimum Wages payable as per Central Labour Wages Acts, 1948.
3. The tender shall be submitted in two cover system. Cover-1 shall contain the letter inviting tender, instructions for tendering, tender conditions, the scope of work, EMD of Rs.40,600/-. Cover-2 shall contain only the Bill of Quantities (Price Bid) i.e. the rate quoted for the contract. Each page of tender shall be signed by an authorized person of the firm and duly stamped. Both the covers shall be super scribed with the name of work.

Cover-1 & Cover-2 shall be put in a third sealed cover super scribing with “Annual Maintenance Contract for deploying Manpower for Plumbing, Carpentry Works and Operation & Maintenance of STP at TIFR at TIFR-Hyderabad, and shall be addressed to the HEAD-Technical Services, TIFR-Hyderabad, Survey No. 36/P, Gopanpally(Village), Serilingampally(Mandal), RR Dist, Hyderabad-500046 on or before 13:00 hrs on 09.09.2020.

**“FINANCIAL BID”:** Signed copy of the Financial Bid quoting amount in the stipulated format and signed copies of the tender drawings.

4. **Earnest Money Deposit (EMD)** EMD shall be submitted in the form of **Demand Draft to be drawn in favour of “TIFR Centre for Interdisciplinary Sciences”, Payable at Hyderabad (To be enclosed with the Technical Bid Part –I)**

**Note:** The bidder/contract should submit a valid NSIC / MSME certificate for exemption of tender fees/EMD

**TATA INSTITUTE OF FUNDAMENTAL RESEARCH**  
**Survey No.36/P, Gopanpally Village, Serilingampally Mandal**  
**Ranga Reddy District, Hyderabad-500046, Telangana**

---

**5. Security Deposit:** The tenderer, whose tender is accepted, will also be required to furnish by way of Security Deposit for fulfillment of his contract, an amount equal to 10% of the tendered value of the work. Earnest Money deposited at the time of tenders will be treated as part of the Security Deposit.

**or**

In case a fixed deposit receipt of any bank is furnished by the contractor to TIFR, Hyderabad as part of the security deposit and the bank is unable to make payment against the said fixed deposit receipt, the loss caused thereby shall fall on the contractor and the contractor shall forthwith on demand furnish additional security to TIFR, Hyderabad to make good the deficit.

All compensation or the other sums of money payable by the contractor under the terms of this contract may be deducted from, or paid by the sale of a sufficient part of his security deposit or from the interest arising there from, or from any sums which may be due to or may become due to the contractor by TIFR or any account whatsoever and in the event of his Security Deposit being reduced by reason of any such deductions or sale as aforesaid, the contractor shall within 10 days make good in cash or fixed deposit receipt tendered by the State Bank of India or by scheduled banks (if deposited for more than 12 months) endorsed in favour of the TIFR, HYDERABAD, any sum or sums which may have been deducted from, or raised by sale of his security deposit or any part thereof.

**6. Acceptance of Tender:** The competent authority, on behalf of TIFR, Hyderabad does not bind itself to accept the lowest or any other tender, and reserves to himself the authority to reject any or all the tenders received, without assignment of any reason. All tenders, in which any of the prescribed condition is not fulfilled or any condition, including that of conditional rebates is put forth by the tenderer, shall be summarily rejected.

The Competent Authority, on behalf of TIFR, Hyderabad reserves to itself the right of accepting the whole or any part of the tender and the tenderer shall be bound to perform the same at the rates quoted. The officer inviting tenders shall have the right of rejecting all or any of the tenders and will not be bound to accept the lowest tender or any other tender.

**V. OTHER MISCELLANEOUS INSTRUCTIONS:**

1. The tender shall be valid for 120 days from the date of submission.
2. The quoted rates shall include minimum wages payable to the employees to be deployed at TIFR-Hyderabad, Survey No. 36/P, Gopanpally (Village), Serilingampally (Mandal), RR Dist, Hyderabad-500046, which are prescribed by Ministry of Labour & Employment, Govt. of India from time to time.
3. The contractor shall also submit the monthly staff payment register to TIFR-Hyderabad for its verification as & when required. The payment shall be made to staff in presence of authorized representative of TIFR Hyderabad or proper documentary proof by way of bank statement shall be furnished.
4. Conditional tenders will not be accepted and be summarily rejected.
5. Tender will be opened at 15:00 hrs. on 09.09.2020 in presence of the representative from each of the tenderers who wish to be present.
6. Price bid of only those tenderers who have satisfied the eligibility criteria as specified in Annexure-I & II shall be considered. The prequalified bidders will be intimated about the date



**TATA INSTITUTE OF FUNDAMENTAL RESEARCH**  
**Survey No.36/P, Gopanpally Village, Serilingampally Mandal**  
**Ranga Reddy District, Hyderabad-500046, Telangana**

---

and time of opening of Cover-2 (Price bid) in advance to enable them to be present at the time of opening.

7. The bids of the applicants who have not furnished EMD and do not meet the eligibility criteria as specified by TIFR-Hyderabad shall be rejected. The unopened Price bid shall be returned to such bidders.
8. Contractors are advised to visit the site before quoting the rate.
9. If any information furnished by the applicant is found to be incorrect at a later date, the tenderers shall liable to be debarred from tendering/taking up the work in TIFR-Hyderabad, TIFR-Hyderabad reserves the right to verify the particulars furnished by the applicant independently.

\* \* \* \* \*

**TATA INSTITUTE OF FUNDAMENTAL RESEARCH**  
**Survey No.36/P, Gopanpally Village, Serilingampally Mandal**  
**Ranga Reddy District, Hyderabad-500046, Telangana**

---

*Annexure - I*

**FORM OF TENDER**

(To be submitted on firm/contractor's letter head along with Part-I Technical Bid)

To,

HEAD-TECHNICAL SERVICES,  
Tata Institute of Fundamental Research  
Sy.No.36/P, Gopanpally (Village)  
Serilingampally (Mandal)  
Ranga Reddy District,  
Hyderabad - 500046, Telangana.

Sir,

**Annual Maintenance Contract for deploying Manpower for Plumbing/Carpentry Works/Operation & Maintenance of STP at TIFR, Survey No. 36/P, Gopanpally (Village), Serilingampally(Mandal), RR Dist, Hyderabad-500046.**

With reference to your Notice for Annual Maintenance Contract for deploying Manpower for Plumbing, Carpentry Works and Operation & Maintenance of STP, I am / we are pleased to offer myself / ourselves for undertaking above work in your esteemed organization. In submission of this offer, we confirm that

- i) We have not made any misleading or false representation in the forms, statements and attachments in proof of the qualification requirements.
- ii) We do not have records of poor performance such as abandoning the work, not properly completing the contract, inordinate delays in completion, litigation history or financial failures etc.
- iii) Business has never been banned by Central / State Government Department/ Public Sector Undertaking or Enterprise of Central / State Government.
- iv) We have submitted all the supporting documents and furnished the relevant details as per prescribed format.
- v) The information and documents submitted with the tender by us are correct and we are fully responsible for the correctness of the information and documents submitted by us.

Yours faithfully,

(Signature of the authorized person  
of the firm/contractor with office seal)

**TATA INSTITUTE OF FUNDAMENTAL RESEARCH**  
**Survey No.36/P, Gopanpally Village, Serilingampally Mandal**  
**Ranga Reddy District, Hyderabad-500046, Telangana**

*Annexure-II*

**Application Form**

**BASIC INFORMATION**

**Annual Maintenance Contract for deploying Manpower for Plumbing/Carpentry Works/Operation & Maintenance of STP at TIFR, Survey No. 36/P, Gopanpally (Village), Serilingampally(Mandal), RR Dist, Hyderabad-500046.**

Sr. No.	Details	To be furnished by the vendor
1	Name of the Contractor / Firm / Organization / Company	
2	Official Address for correspondence with Telephone & Mobile Nos.	
3	Correspondence address at Hyderabad with contact person's name, telephone number, mobile number etc. (The company should have office and service facilities at Hyderabad)	
4	Type of Firm / Organization, whether proprietorship, partnership or private PUBLIC company etc.	
5	Year of establishment	
6	Name of the Proprietor / Partner / Directors in Organization	a) b) c) d)
7.	a) Details of Registration (Firm, Company etc.)	To be filled by the vendors

**TATA INSTITUTE OF FUNDAMENTAL RESEARCH**  
**Survey No.36/P, Gopanpally Village, Serilingampally Mandal**  
**Ranga Reddy District, Hyderabad-500046, Telangana**

	<p>i. Registering Authority  ii. Date  iii. Number</p> <p>b) Details of Labour license  i. Registering Authority  ii. Reg No.  iii. Date of issue  iv. Date of expiry</p> <p>c) Details of Contractor's/Works license  i. Registering Authority  ii. Reg. No.  iii. Date of Issue  iv. Date of expiry  <b>(Copies to be enclosed)</b></p>	
8	<p>a) Details of Income Tax Permanent Account Number  b) Details of EPF No.  c) Details of ESI No.  d) Details of GST No.  <b>(Enclose a copy of the certificate issued by competent authority)</b></p>	
9.	<p>Annual average turnover of the contractor during last 3 years ending March 31, 2020 should be at least Rs.....lakhs (latest 3 years)</p> <p>The annual turnover format is given at page No. XX and should be duly signed and stamped by the CA on the letterhead</p>	
10	<p>Whether registered / empanelled with any of the Govt. Semi Govt., MES, IIT, NIT, IISc, Govt. Undertaking, Public Sectors etc. as approved contractors and if so, furnish details</p>	
11	<p>Whether any technical personnel are employed with the Firm / Organization and if so, give details of their experience, qualification</p>	

**TATA INSTITUTE OF FUNDAMENTAL RESEARCH**  
**Survey No.36/P, Gopanpally Village, Serilingampally Mandal**  
**Ranga Reddy District, Hyderabad-500046, Telangana**

---

12	If involved in any litigation earlier with any organization. If so, please submit the details.	
13.	Any civil suits pending in any of the works executed. If so, furnish details.	

Date:

Signature of authorized person & seal:

**TATA INSTITUTE OF FUNDAMENTAL RESEARCH**  
**Survey No.36/P, Gopanpally Village, Serilingampally Mandal**  
**Ranga Reddy District, Hyderabad-500046, Telangana**

---

**EXPERIENCE**

**Annual Maintenance Contract for deploying Manpower for Plumbing/Carpentry Works/Operation & Maintenance of STP at TIFR, Survey No. 36/P, Gopanpally (Village), Serilingampally(Mandal), RR Dist, Hyderabad-500046.**

**A) List of similar works / contracts being executed presently by the contractor / Firm / Organization:**

Sr. No.	Name of the work	Name & Address of the Company for whom the work was executed	Nature / Type of the Work	Name, Address & mobile/phone No. of Officer / person under whom the work was carried out	Work Order No. and Date	Estimated value of the work (Rs.)	Duration of the Contract with commencement and expected date of completion date	Remarks
1.								
2.								
3.								
4.								
5.								

**Note:** Copy of the work order, completion and performance certificate should be enclosed for each work.

**TATA INSTITUTE OF FUNDAMENTAL RESEARCH**  
**Survey No.36/P, Gopanpally Village, Serilingampally Mandal**  
**Ranga Reddy District, Hyderabad-500046, Telangana**

**B) List of similar works / contracts executed by the contractor / Firm / Organization during the last 7 years prior to June 30, 2020:**

Sr. No.	Name of the work	Name & Address of the Company for whom the work was executed	Nature / Type of the Work	Name, Address & mobile/phone No. of Officer / person under whom the work was carried out	Estimated value of the work (Rs.)	Duration of the Contract with commencement and expected date of completion date
1.						
2.						
3.						
4.						
5.						

**Note:** Copy of the work order, completion and performance certificate should be enclosed for each work.

**C) Audited Annual Turnover for the last 3 years:**

Sr. No.	Financial / accounting Year	Profit (Rs.)	Loss (Rs.)	Annual Turnover (in INR)
1.	2017-2018			
2.	2018-2019			
3.	2019-2020			

**Note:** The Audited Annual Turnover (Latest 3 Years) should be certified by Chartered Accountant (CA) as per the format given above duly signed and stamped by the CA on their letterhead.

Date:

Signature of authorized person & seal:

**SCOPE OF WORK**

**Annual Maintenance Contract for deploying Manpower for Plumbing/ Carpentry Works**  
**/Operation & Maintenance of STP at TIFR at TIFR, FReTB, Survey No. 36/P,**  
**Gopanpally(Village), Serilingampally(Mandal), RR Dist, Hyderabad-500046.**

The Contractor shall attend to all the works 24x7 basis and post One Highly Skilled NGPSTP operator (ie. from 9:00 am to 5:00 pm,). The contractor shall provide minimum one-day duty off once in a week for the employees working in shifts and shall provide relievers for the employees on off duty / sick / leave. However, in case of exigencies, the contractor shall provide services beyond above mentioned hours. The process flow diagram (PFD) and details of the pumps and tanks are as under

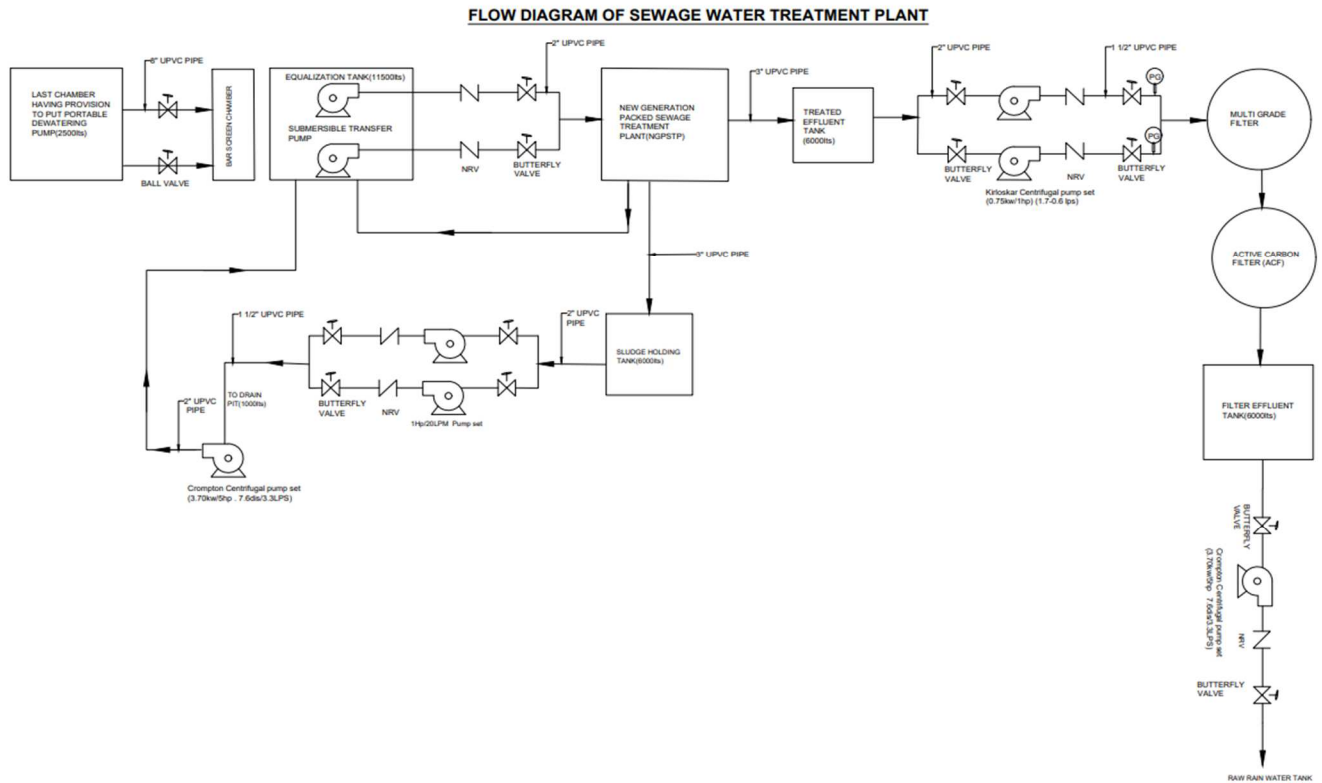



**TATA INSTITUTE OF FUNDAMENTAL RESEARCH**  
**Survey No.36/P, Gopanpally Village, Serilingampally Mandal**  
**Ranga Reddy District, Hyderabad-500046, Telangana**

Sr. No.	Description	Capacity	Location
1	Collection Tank	2500 lts	Service Building -2
2	Equalization Tank	11500 lts	Service Building-2
3	NGPSTP	30KLD	Service Building-2
4	Treated Effluent Tank	6000 lts	Service Building-2
5	Multi grade filter.	600 Ø	Service Building-2
6	Activated Carbon	600 Ø	Service Building-2
7	Filter Effluent Tank	6000 lts	Service Building-2
8	Sludge Holding Tank	6000 lts	Service Building-2

### **1. Scope of work for STP**

- Operation, Monitoring of complete STP plants and maintaining log sheet.
- Checking the level of sewage collected in the Equalization Tank.
- Sewage transfer pump operation.
- Maintain the constant flow from the equalization tank to NGPSTP.
- Checking the level of STP tank.
- Greasing and oil should be checked regularly.
- Media cleaning to be done as and when required by contractor.
- Make sure that blower should run round the clock.
- Prepare the hypo chlorine solution of required ppm.
- Daily check the level of chlorine storage tank.
- Setting up of dosing ppm as per the outlet quality.
- Main the daily consumption of Sodium hypochlorite (Payments to be made as per actual consumption) in a log book.
- Checking the level of Filter feed tank.
- Manual checking of suspended solid.
- If the suspended solids are present in the filter feed tank, checking of proper settlement in the secondary settling tank.
- Maintenance and checking of Filter feed water pump.
- Normal operation of multi grained filter (MGF) & activated carbon filter (ACF) as per the instruction given in the manual.
- Backwash of MGF & ACF based on differential pressure.
- Prolonged backwash of MGF & ACF as and when required.
- Rinsing of MGF and ACF filters when required.
- Monitoring the quality and recording in the logbook and status report.
- Effluent analysis would be carried out by contractor, once in a month.
- **Technical audit would be carried out by our technical services team of contractor**

**TATA INSTITUTE OF FUNDAMENTAL RESEARCH**  
**Survey No.36/P, Gopanpally Village, Serilingampally Mandal**  
**Ranga Reddy District, Hyderabad-500046, Telangana**

---

**once in 6 Months.**

- Monthly once Engineer visit to STP for monthly monitoring of treatment process.
- Training will be provided to operator by contractor, if required.
- The detailed schedule of operation, routine, special and preventive maintenance along with daily, fortnightly, monthly activities for all the works and execute as per the direction of Engineer in Charge. However tentative minimum routine and preventive schedule shall be as under:

**Daily Checks:**

- Checking the level of sewage collected in the Equalization Tank.
- Maintain the constant flow from the equalization tank to NGPSTP.
- Checking the level of STP tank.
- Media cleaning to be done.
- Make sure that blower should run round the clock.
- Check the level of chlorine storage tank.
- Setting up of dosing ppm as per the outlet quality.
- Maintain the daily consumption of Sodium hypochlorite in a log book.
- Checking the level of Filter feed tank.
- Manual checking of suspended solid.
- Backwash of MGF & ACF based on differential pressure.

**Monthly checks:**

- Greasing and oil should be checked regularly.
- Make sure that blower should run round the clock.
- Prepare the hypo chlorine solution of required ppm.
- Maintenance and checking of Filter feed water pump.
- Effluent analysis would be carried out.

**2. Maintenance & Cleaning:**

Besides the above routine works, the scope of work shall include removing of sludge from STP, cleaning the all equipment which belongs to STP, arresting leakages in the water supply and sanitary lines by using zinc and spun yarn/cement, removal of chokes from STP inlet & outlet lines

**3. Manpower:**

Contractor shall attend to post One Skilled (Should be of ITI background with one year experience) in general Shifts (ie. from 9:00 am to 5:00 pm) on all days; on weekly six days during the entire contract period for operation & maintenance of the above said works.

**4. Replacement of Spares:**

- i. Cost of individual spares i.e. more than Rs. 100/- required for replacement/maintenance of the STP items, shall be borne by TIFR-Hyderabad.

**TATA INSTITUTE OF FUNDAMENTAL RESEARCH**  
**Survey No.36/P, Gopanpally Village, Serilingampally Mandal**  
**Ranga Reddy District, Hyderabad-500046, Telangana**

---

- ii. The necessary vouchers /invoices are required to be submitted for items payable by TIFR-Hyderabad for settlement of their bills along with the DC duly and work completion certificate duly certify by the TIFR Officials/Engineer.. In such case, TIFR-Hyderabad shall pay cost of materials on actual plus 15% towards overhead and profit and no extra payment towards labour will be made.
  - iii. Any other items i.e. Washer, Nuts, Bolts, Clamps etc. costing less than Rs. 500/- shall be borne by the contractor and no extra payment will be made.
  - iv. For all the works mentioned in (i), contractor is advised to submit the comprehensive bill including DC and work completion certified by the TIFR Officials/Engineer along with the monthly bill.
4. Operator should have proper uniform with continuous display of Identity Card. Operator should be provided with a tool bag containing all the necessary tools.
- 5. The following Plumbing tools and machinery shall be provided by the contractor:**
1. Cutting Player
  2. Monkey Player
  3. Screw Drivers
  4. Spanners
  5. Hammer
  6. Adjustable Wrench
  7. Pipe Wrenchs
  8. Hacksaw
  9. Pipe Cutter
  10. Measurement Tape
  11. Plunger
6. Arrange visit of STP engineer (must be holder of Environmental B-Tech or M-Tech should be able to certify the water quality test report) once in a Month for inspection and submit report to TIFR-Hyderabad's Engineer about his observations. He should also visit whenever major repairs of STP in the premises of TIFR-Hyderabad. Details regarding Skilled Operator i.e. Name, Qualification, Experience shall be given at the time of submission of tender.
7. The contractor is required to maintain following registers during the job of AMC:
- i) Daily inlet & outlet water register
  - ii) Daily plant running time register
  - iii) Daily Backwashing register
  - iv) Checklist as per scope of work
  - v) Shift report register
  - vi) Daily consumable register and payment to be made on actuals.
8. Contractor shall follow the prescribed formats/procedures for receiving complaints, receiving the work slips duly sanctioned and preparation of bills etc. as stipulated by TIFR-Hyderabad from time to time.

**TATA INSTITUTE OF FUNDAMENTAL RESEARCH**  
**Survey No.36/P, Gopanpally Village, Serilingampally Mandal**  
**Ranga Reddy District, Hyderabad-500046, Telangana**

9. Contractor shall maintain a proper record/register indicating reasons for not attending to any particular complaint within time schedule, failing which penalty shall be levied.

**SCOPE OF PLUMBING AND CARPENTER WORKS**

Annual Maintenance Contract for deploying Manpower for **Plumbing Works** - Operation & Maintenance of Water Supply, Sewerage, Sanitation, Plumbing including servicing of Sanitary fittings & fixtures, Rain water harvesting system, RO Water Plant and Fire Fighting installations on 24x7 basis and post one skilled worker (Assistant Plumber cum Fitter cum Mechanic) in 2 shifts (i.e. from 6:00 am to 2:00 pm, 2:00 pm to 10:00 pm) on all days during the entire contract period and **Carpentry Works** - post one skilled carpenter on general shift weekly six days (i.e. 9:0 AM to 5:00 pm) at TIFR-Hyderabad.

**A. Plumbing Works:**

1. i. Operation and maintenance of the Water Supply, Sewerage, Sanitation, Plumbing including servicing of Sanitary fittings & fixtures, Rain water Harvesting System, RO Water Plant and Fire Fighting installations at TIFR-Hyderabad, Survey No.36/P, Gopanpally (Village), Serilingampally (Mandal), RR Dist, Hyderabad-500046.
- ii. Monitoring of supply from HMWS&SB line, water supply line, sanitary sewage line within the building and up to municipal line/supply line in day to day basis.
- iii. Operation of pumps, for continuous storage in Underground (U/G) & Overhead Tanks (OHT) as under:

**A. Pumps & Filters**

Sr. No.	Description	Capacity	Location
1	Domestic water pumps- 2 Nos	100 LPM @ 45m head	Dry well – Service Building -1
2	Rain Water Harvesting System	72000 Ltr/ Hr	Basement- Service Building-2
a	Feeding pumps- 3 Nos	1200 LPM@ 15m head	Basement- Service Building-2
b	Dosing pumps for chlorination & alum- 3 Nos.	10 Ltr/ hr (Rating)	Basement- Service Building-2
c	Sand Separators (Hydrocyclone filter)- 3 Nos.	120 Cum/Hr.(Filter rate) Working Pressure-5Kg / Sqcm-	Basement- Service Building-2
d	Pressure filters- 3 Nos	125 Cum/Hr (Filter rate) Working Pressure- 2.5Kg / Sqcm	Basement- Service Building-2
e	Chemical Storage Tanks- 2Nos for dosing usage (Sodium Hypochlorite)	100 Ltr each for STP and Rain water harvesting plant	Basement- Service Building-2
f	Rain water(filtered) flushing pumps- 2 Nos	35 LPM	Basement- Service Building-2
3	Bore well submersible pumps- 3 Nos.	50 LPM@130m head	Each at NE Corner of Campus, Behind Service

**TATA INSTITUTE OF FUNDAMENTAL RESEARCH**  
**Survey No.36/P, Gopanpally Village, Serilingampally Mandal**  
**Ranga Reddy District, Hyderabad-500046, Telangana**

			Building-1 and Behind Service Building-2
4	RO water pumps -2 nos	200 LPH RO Unit, Feeder pump - 1 no, Booster pump- 1 no	RO water pump room at terrace of main building , Right side.

**B. Water Tanks:**

Sr. No.	Description	Capacity	Location
1	OHT (Domestic) - 2 Nos x10000 Ltr	20000 Ltr	Main Building
2	OHT(Fire Fighting) - 2 Nos x 20000 Ltr	40000 Ltr	Main Building
3	OHT(Flush water) - 2 Nos x 5000 Ltr	10000 Ltr	Main Building
4	OHT(Gardening) – 2 Nos x 20000 Ltr	40000 Ltr	Main Building
5	OHT (Domestic) - 1 Nos x10000 Ltr	10000 Ltr	Service Building-1
6	OHT(Fire Fighting) - 1 Nos x 10000 Ltr	10000 Ltr	Service Building-1
7	OHT(Flush water) - 1 Nos x 5000 Ltr	5000 Ltr	Service Building-1
8	OHT (Domestic) - 1 Nos x 5000 Ltr	5000 Ltr	Service Building-2
9	OHT(Fire Fighting) - 1 Nos x 20000 Ltr	20000 Ltr	Service Building-2
10	OHT(Flush water) - 1 Nos x 2000 Ltr	2000 Ltr	Service Building-2
11	UG Tank (Domestic) - 1 Nos x 100000 Ltr	100000 Ltr	Service Building-1
12	UG Tank (Fire Fighting) - 2 Nos x 200000 Ltr	400000 Ltr	Service Building-1
13	UG Tank ( Rain water collection tank) - 1 Nos	350000 Ltr	Service Building-2
14	UG Tank (Filtered Rain water tank) - 2 Nos	1475000Ltr	Service Building-2
15	Water Meter Chamber(HMWSSB) -1Nos	73000 Ltr/hr	NE Corner of Campus,
16	RO Water storage tanks - 2 Nos	500 Ltr each	Terrace of main building, Right wing.

**2. Maintenance & Cleaning:**

- i. Besides the above routine works, the scope of work shall include arresting leakages in the water supply and sanitary lines by using zinc and spun yarn/cement, removal of chokes from water closets, urinals, wash basins, sinks, floor traps, soil and waste pipes, rain water pipes, porcelain traps and underground drain lines and water lines inside the compound. Also making holes in stone/brick masonry and RCC walls of any size, roofs, chajjas etc. to facilitate plumbing works etc. and providing scaffolding wherever required.

**TATA INSTITUTE OF FUNDAMENTAL RESEARCH**  
**Survey No.36/P, Gopanpally Village, Serilingampally Mandal**  
**Ranga Reddy District, Hyderabad-500046, Telangana**

---

- ii. Carrying out cleaning of all the water tanks indicated in iii. B (Page No.20) above of building once in 3 (three) months (i.e. four cleaning per year). Cleaning should be carried out with water pressure type machine, disinfecting materials such as bleaching powder, potassium permanganate. Cost of above materials is included in the scope of work and no extra payment shall be made in this regard.
- iii. All terraces in the buildings, which are provided with rainwater outlets are required to be cleaned for any dead leaves, silt etc. once in 15 days or as & when required. The debris collected shall be disposed off in the municipal garbage site provided near the building.
- iv. All Trap provided near the canteen and lounge shall be cleaned once a week by opening the manhole covers and removing the obstacles, if any, from the chambers. The lines shall be flushed and kept free of any trapped oil etc.
- v. Besides maintenance and operation of water pumps, sump pumps and rain water harvesting system pumps, control panel for sump pumps, RO Water pumps the scope of work shall also include regular servicing/maintenance pumps & installations like oiling, greasing, replacement of gasket packing etc. twice a month & in case of emergency breakdown, by a specialized agency in basement & on any floors, work may be carried out as directed by TIFR-Hyderabad.
- vi. Periodical checking of drain pipes, rain water pipes and storm water drains before and during monsoon to ensure proper flow and avoid choking in pipes/drains.

### **3. Manpower:**

Contractor shall attend to all the works on 24x7 and post One Skilled worker ((Should be of ITI background with one year experience)) in 2 Shifts (ie. from 6:00 am to 2:00 pm, 2:00 pm to 10:00 pm) on all days during the entire contract period for operation & maintenance of the above said works.

### **4. Replacement of Spares:**

- i. Cost of individual spares i.e. more than Rs. 100/- such as bottle trap, flush valve, seat cover, bib tap etc. required for replacement/maintenance of the plumbing/sanitary items, shall be borne by TIFR-Hyderabad.
- ii. The necessary vouchers /invoices are required to be submitted for items payable by TIFR-Hyderabad for settlement of their bills along with the DC duly and work completion certificate duly certify by the TIFR Officials/Engineer.. In such case, TIFR-Hyderabad shall pay cost of materials on actual plus 15% towards overhead and profit and **no extra payment towards labour will be made.**
- iii. Any other items i.e. Washer, Nuts, Bolts, Clamps etc. costing less than Rs. 100/- shall be borne by the contractor and no extra payment will be made.
- iv. For all the works mentioned in (i), contractor is advised to submit the comprehensive bill including DC and work completion certified by the TIFR Officials/Engineer along with the monthly bill.

**TATA INSTITUTE OF FUNDAMENTAL RESEARCH**  
**Survey No.36/P, Gopanpally Village, Serilingampally Mandal**  
**Ranga Reddy District, Hyderabad-500046, Telangana**

---

5. Plumbers should have proper uniform with continuous display of Identity Card. Each plumber shall be provided with a tool bag containing all the necessary tools.
6. **The following Plumbing tools and machinery shall be provided by the contractor:**
  1. Cutting Player
  2. Monkey Player
  3. Screw Drivers
  4. Spanners Set
  5. Drilling Machine
  6. L-Angle Set
  7. Hammer
  8. Adjustable Wrench
  9. Pipe Wrenches
  10. Hacksaw
  11. Pipe Cutter
  12. Measurement Tape
  13. Plunger
  14. Angle Grinder
  15. Cordless Combi Drill
  16. Chipping machine
7. Arrange visit of plumbing engineer once in a quarter for inspection and submit report to TIFR-Hyderabad's Engineer about his observations. He should also visit whenever major repairs of existing pipelines in the premises of TIFR-Hyderabad. Details regarding Skilled Operator i.e. Name, Qualification, Experience shall be given at the time of submission of tender.
8. The contractor is required to maintain following registers during the job of AMC:
  - i) Daily pump operation register
  - ii) Daily water tank filling register
  - iii) Daily checking of toilets attending the faults/complaints
  - iv) Checklist as per scope of work
  - v) Shift report register
9. Contractor shall follow the prescribed formats/procedures for receiving complaints, receiving the work slips duly sanctioned and preparation of bills etc. as stipulated by TIFR-Hyderabad from time to time.
10. Contractor shall maintain a proper record/register indicating reasons for not attending to any particular complaint within time schedule, failing which penalty shall be levied.
11. The detailed schedule of operation, routine, special and preventive maintenance along with daily, fortnightly, monthly activities for all the works and execute as per the direction of Engineer In Charge. However tentative minimum routine and preventive schedule shall be as under

**TATA INSTITUTE OF FUNDAMENTAL RESEARCH**  
**Survey No.36/P, Gopanpally Village, Serilingampally Mandal**  
**Ranga Reddy District, Hyderabad-500046, Telangana**

---

**Daily Checks:**

- Monitoring of water supply from HMWS & SB lines, checking of water storage in UG sumps with supply from HMWS&SB. Maintaining records such as water meter reading, water storage levels in sumps etc.
- Pumping of domestic water to all terrace tanks. Maintaining records of water pumping.
- Pumping of flush water from filtered water storage tank to all terrace tanks. Maintaining records of water pumping.
- Pumping of water from filtered water storage tank to all terrace gardening water tanks. Maintaining records of water pumping.
- Pumping of domestic water to 200 lph RO water plant at terrace. Maintaining water level records.
- Checking of all water lines (internal & external) relating to HMW&SB, domestic, flushing, gardening, bore water, firefighting and RO water lines against leakage.
- Checking of water supply fittings, fixtures in labs and toilets.
- Checking of drain pipe lines in labs and toilets against choking.
- Checking of sewer lines to ensure proper flow in pipes.
- Visual Checking of electrical panel relating to pumps of domestic, flushing, bore well, RO water supply.
- Maintain check sheets, various registers etc properly.
- Submission of daily shift reports to E.I.C.
- Constantly coordinate with AMC Vendors of RO Water Plant & NGPSTP in case of any breakdown/problem/monthly checks etc. and get the service done by them.

**Weekly checks:**

- Functioning and service checking of all pumps and accessories relating to domestic, flushing, gardening, rain water harvesting, firefighting, RO water systems.
- Checking of Gully traps, manholes relating to sewer lines against choking.

**Monthly checks:**

- Proactive plumbing preventive maintenance i.e. checking of active leaks, water pressure, sign of corrosion, checking of valves for correct operation, checking drains against clogging etc.
- Checking of all firefighting water pipe lines, fire hydrants, fire hoses, fire hose box, Hose reels, pressure gauge and pressure switch.
- Replacing of gasket & Washer ( if leakage/faulty are noticed)

**Quarterly checks:**

- Cleaning of terrace water tanks.
- Cleaning of underground sumps of domestic and firefighting.



**TATA INSTITUTE OF FUNDAMENTAL RESEARCH**  
**Survey No.36/P, Gopanpally Village, Serilingampally Mandal**  
**Ranga Reddy District, Hyderabad-500046, Telangana**

---

- Cleaning of filtered rain water underground storage tanks.
- Cleaning of rain water spouts free from dead leaves and dust accumulation.
- Cleaning of R.O. water storage tanks.

**Half yearly checks**

- Cleaning of storm water drains to ensure free flow of water in drains during monsoon.
- Cleaning of rain water collection tank.

**B. CARPENTRY WORKS:**

Providing the services of skilled carpenter with Uniform & Identity Card on general shift (i.e. from 09:00 am to 5:00 pm) on weekly six days during the entire contract period, along with essential tools to attend to day to day maintenance and repair/ replacement of carpentry fittings at TIFR Hyderabad . (Should be of ITI background with one year experience)

- Attending to all the complaints mentioned in complaint Register/received in writing relating to carpentry and allied works and rectifying the defects wherever necessary including cost of minor materials (with necessary tools and minor items like adhesives, screws, nails, nut & bolt, washer, brackets, clips etc. as well as items/works costing individually upto Rs.100/-) replaced in the premises.
- Repairing of Wooden door, Wooden cabinets, Wooden Table, shelves, cupboards, pelmets and other wooden members, chairs etc. attending to necessary repairs and adjustments for easy operation of shutters using necessary commodities similar to the existing one for filling up the holes, if any, in the frames. Replacement of wood, veneer, laminates, door closer and glass will be paid extra.
- Repairing of aluminum windows, doors, ventilators, partitions cutting and removing the damaged sections, replacing with suitable aluminium sections for frames, styles and rails, gaskets, attending to necessary repairs and adjustments for easy operation of shutters using necessary commodities similar to the existing one for filling up the holds, if any, in the walls. Replacement of aluminum section, laminated particle boards , door closer and glass will be paid extra.
- Repairing of MS doors, gate rolling shutters ,ms grills by cutting and removing the damaged portions, replacing with suitable MS sections for frames, shutters, attending to necessary repairs and adjustments for easy operation of shutters using necessary commodities similar to the existing one for filling up the holes, if any, in the frames. Replacement of MS sections, members and glass will be paid extra as well as for arrangement of welding machines & welder.

**TATA INSTITUTE OF FUNDAMENTAL RESEARCH**  
**Survey No.36/P, Gopanpally Village, Serilingampally Mandal**  
**Ranga Reddy District, Hyderabad-500046, Telangana**

---

- Making holes in stone/brick masonry and RCC wall of any size, roofs, chajjas, etc. to facilitate Civil, plumbing and carpentry works and making good the same wherever necessary.
- Rectifying and replacing hooks, hinges, aldrops, tower bolts, knobs, handles, door locks, door closers, door stoppers, floor springs, hold fasts, bearing, clamps, picture hooks, nails, screws, nylon rope and brackets for cloth drying arrangement etc. , with suitable material like the existing one Leveling of doors and window surfaces to ensure proper functioning of doors, windows ventilators etc.
- Fixing and replacement of glass panes to windows ventilators of different sizes at all places including fixing of putty to existing glass panes of windows.
- Repairing of workstation, installing necessary fixtures wherever needed.
- Any other work not covered above but related to carpentry.

**List of tools**

- Hand saw
- Spirit level
- Claw hammer
- Chisel
- Nail gun
- Drill machine
- Quick clamp
- Block plane
- Trimming or utility knife
- Circular saw
- Screw drivers
- Clamp
- Carpenter square
- Work bench
- Measurement tape

**‘PENALITY’ CLAUSE:**

The Availability & functioning of Water supply, Sewerage, Sanitation and Plumbing system is very essential and critical. Non-availability may result many tangible & non tangible losses in research work, equipment, animals, tissues etc.

Hence all the work routine, servicing, breakdown maintenance has to be carried out in accordance with all standards and statutory norms with minimum time and maximum accuracy to ensure maximum availability.

Contractor should depute experienced personnel to carry out maintenance work both low & high side in such a way that the repetition of the problem should be avoided.

Failure in meeting the above requirements will attract the ‘fine’ clause as below.

- a) **Absenteeism:** No absenteeism shall be allowed. In case of absence of any staff in the agreed staff pattern, fine will be imposed at **one and half times the rate for the day** the staff remains absent.
- b) **Non-Compliance of work:** In the event of failure of compliance of awarded work in stipulated time fine will be imposed as per **double of actual expenditure incurred** in attending the same by other agency.

TIFR-Hyderabad / concerned engineer will be authorized to deduct amount from the contractor bill or security deposit or initiate any other action as found suitable.

\* \* \* \* \*

**INSTRUCTIONS FOR TENDERERS**

1. Before filling up the tender, the tenderers are requested to visit the site and also carefully examine the tender documents, conditions of contract, specifications, scope of work etc. The tenderer shall ascertain the location, size and condition of the areas available for his use as working areas and all other information affecting his tender.
2. Service is the essence of the contract and the systems (water supply and plumbing and sanitary/drainage system and Rain water harvesting systems must be maintained efficiently as indicated in the Appendix to Form of Tender. Any tenderer, which disagrees with terms & conditions of the tender, is liable to be rejected.
3. The tender form and the documents attached to it shall not be detached one from the other and no alteration or mutilation (other than filling in all blank spaces) shall be made in any of the documents attached hereto.
  - i) The tenderer shall completely fill the required Annexure and Price Bid. The tender shall be signed by person or persons so authorized by the tenderer with signature duly witnessed. The tenderer shall sign each of the document pages and duly stamped.
  - ii) The tender shall contain postal address, e-mail ID, Tel. no. and Fax. No. for correspondence/servicing instructions, required to be served to the tenderer in connection with tender/contract.
4. The tender shall accompany the following information & schedules:
  - a) Details of past/present experiences in performing works/contracts of similar nature and magnitude.
  - b) True copy of PAN, GST registration.
5. TIFR-Hyderabad will not be responsible and will not pay any expenses which may have been incurred, or losses to person or property suffered by the tenderer in connection with visits and examination of the site and in the preparation of the tender for submission.
6. The vendor (whether or not he submits the tender) shall treat the details of the document as secret and confidential.
7. TIFR-Hyderabad reserves the right to adjust arithmetical or other errors in any tender in the way, which he considers suitable. Any adjustments so made by TIFR-Hyderabad shall be stated to the tenderer if TIFR-Hyderabad makes an offer to accept his tender.
8. The service charges would be payable on the completion of one month service and on submission of the bills. In case of unsatisfactory performance, TIFR-Hyderabad may terminate the contract by giving 1 (One) month notice. However, the contractor shall give 3 (three) months' notice to TIFR-Hyderabad in case he decides to terminate the contract.

**TATA INSTITUTE OF FUNDAMENTAL RESEARCH**  
**Survey No.36/P, Gopanpally Village, Serilingampally Mandal**  
**Ranga Reddy District, Hyderabad-500046, Telangana**

---

9. TIFR-Hyderabad is not bound to accept the lowest or any tender and has the right to refuse any tender without assigning any reason. TIFR-Hyderabad also has right to re-issue the tender without tenderers having the right to object to such re-issue.

\* \* \* \* \*

**General Terms & Conditions**

1. The contractor shall provide the maintenance services as given in ‘Scope of Work’ to the satisfaction of the TIFR-Hyderabad. The performance of the contractor shall be reviewed on monthly basis and in case the services are not found to be satisfactory, the contract shall be terminated even before the expiry of contract period by giving one month’s notice. However, the contract is liable for immediate termination on violation of any of the provisions by the contractor. The TIFR-Hyderabad may also terminate the contract in the instance of insolvency or bankruptcy of the contractor or change of ownership of the business of the contractor. The TIFR-Hyderabad shall not pay any compensation for early termination. The security deposit/performance bank guarantee submitted under the contract shall be liable to be forfeited and shall be absolutely at the disposal of TIFR Hyderabad.
2. All the bidders/contractors should provide Company Authorization Letter duly signed and stamped by Authority to participate in the Pre Bid Meeting, Technical bid opening and Financial bid opening etc.
3. If the contractor fails to execute the maintenance works as detailed in ‘Scope of Work’ within stipulated time, the TIFR-Hyderabad will be at liberty to execute the works through an alternate source and the charges so incurred shall be recovered from the contractor.
4. The contractor shall permit the TIFR-Hyderabad to hold or deduct the amount from bill for non-performance or part performance or failure to discharge obligations under this contract.
5. Security Deposit: The successful tenderer will have to submit Security Deposit @ 10% of the total work order value in the form of account payee demand draft/bank guarantee from SBI or any one of the nationalized banks in an acceptable form. Security Deposit should remain valid for a period of fourteen months from the date of commencement of Contract and would be released only after settlement of all dues of the contract. The deposit shall not bear any interest.
6. The contractor shall obtain at his own cost, any license or permission of any sort whatsoever (viz., labour license from Assistant Labour Commissioner (Central), Hyderabad and register with Employees’ State Insurance.
7. Corporation and Office of the Regional Provident Fund Commissioner, Hyderabad, GST, Income Tax etc.) that may be required under various Acts from the Central/State Government Authorities for carrying out the said activity in the premises of the TIFR-Hyderabad and such Registrations and License for engagement of contract workers for such purpose should be obtained by the contractor within one month from the date of issue of work order.

**TATA INSTITUTE OF FUNDAMENTAL RESEARCH**  
**Survey No.36/P, Gopanpally Village, Serilingampally Mandal**  
**Ranga Reddy District, Hyderabad-500046, Telangana**

---

8. The contractor shall comply with the provisions of all Labour Laws, which are applicable to 'the Contractor' or his employees and shall be solely responsible for liabilities arising out of such compliance, non-compliance or implementation or non-implementation. The contractor will furnish proof of compliance of all Labour Laws requirements including obtaining licenses, filing of monthly/quarterly/annual returns and any other statutory requirement and furnish calculations and proof of payments made to all Government/Statutory Authorities under EPF, ESIC, Labour Welfare Fund Act, Payment of Bonus Act, etc. within time limit allowed under the respective Acts and all other statutory rules as amended from time to time. TIFR Hyderabad will not be responsible if the contractor is not satisfying any statutory compliances etc.
9. The contractor shall indemnify the TIFR-Hyderabad from all liabilities arising out of any payment/ in respect of any claims made by the contractor's employees against the TIFR-Hyderabad under any statute/notification of the Government (Central/State) or statutory authority in respect of his employees.
10. The contractor shall be responsible for maintenance of proper records as required under the provisions of various Labour Laws / Statutory Acts applicable to the contractor and contract employees such as attendance register, overtime register, advance register, register of deductions for damage & loss, register of fines, accident register etc. and produce them for inspection as and when demanded by TIFR-Hyderabad or any appropriate Labour authorities. The contractor shall also issue Form-XIV (employment card) to their personnel.
11. The contractor shall make the payment to personnel engaged by him as per minimum wages notified by the Office of the Regional Labour Commissioner (Central), Hyderabad from time to time. The contractor shall satisfy the TIFR-Hyderabad showing adequate recorded proof that the minimum wages, ESI, contribution to provident fund as applicable are being paid to his personnel as required under various Statutory Acts notified by the Government from time to time. **The contractor shall disburse wages payable to his personnel only in the presence of an authorized officer of the TIFR-Hyderabad or furnish the proof of salary remittance (Bank Statement).**
12. The contractor shall provide weekly off / holidays to his personnel as per applicable laws/ labour laws but it will be his responsibility to ensure uninterrupted services on all days.
13. The contractor shall ensure that the character and antecedents of the personnel engaged by him are duly verified before such engagement.
14. The contractor shall submit the list of his personnel to be deployed at the TIFR-Hyderabad along with their personal details like name, age, date of birth, permanent address etc. for approval. The TIFR-Hyderabad has the right to advise the contractor to replace any of the personnel engaged by him who are found unsuitable; the contractor shall immediately replace such personnel. The contractor shall provide identity cards to his personnel.

**TATA INSTITUTE OF FUNDAMENTAL RESEARCH**  
**Survey No.36/P, Gopanpally Village, Serilingampally Mandal**  
**Ranga Reddy District, Hyderabad-500046, Telangana**

---

15. The contractor shall not employ any person who is prohibited by law from being employed. The personnel deployed by the contractor should not suffer from any infectious disease and should be able-bodied persons.
16. The contractor shall ensure that none of his personnel report for duty in drunken state or consume drugs, prohibited substances, smoke, etc., while on duty.
17. The contractor shall take necessary safety measures and he/she is solely responsible for the safety of personnel engaged by him. **The contractor shall provide appropriate uniform, shoes, gloves, accessories & tools that would ensure safety against insects & snakes, dogs and electrocution to all personnel and ensure their cleanliness and upkeep.**
18. The TIFR-Hyderabad shall not be responsible for any accident/injury or loss of life of any of the persons engaged by the contractor that may take place while executing the contract. Any compensation or expenditure towards the treatment of such injury or loss of life shall be sole responsibility of the contractor. At his cost, the contractor shall obtain appropriate/adequate insurance policy to his personnel towards meeting the liability of compensation arising out of death, injury, disablement, etc. at work.
19. The contractor shall abide by all the rules and regulations laid down by the TIFR-Hyderabad authorities from time to time.
20. The contractor or his personnel shall not any time do, cause or permit any nuisance at the site / do anything which shall cause unnecessary disturbances or inconvenience to the occupants/visitors at site or near the site of work.
21. The contractor shall be responsible for all acts done by the personnel engaged by him and for maintenance of proper discipline by his personnel at the premises of the TIFR-Hyderabad. Any act of indiscipline/misconduct/theft/pilferage on the part of any personnel engaged by the contractor resulting any loss to the TIFR-Hyderabad in kind or cash will be viewed seriously and the TIFR-Hyderabad shall have the right to levy damages or fine from the contractor and even terminate the contract forthwith.
22. Care must be taken to ensure while carrying out the work so that no laboratory equipment, fittings, fixtures, furnishings are damaged. Any damages done to the same or any other property will have to be repaired / replaced by the contractor, failing which the TIFR-Hyderabad will get them repaired/replaced at risk and cost of the contractor.



**TATA INSTITUTE OF FUNDAMENTAL RESEARCH**  
**Survey No.36/P, Gopanpally Village, Serilingampally Mandal**  
**Ranga Reddy District, Hyderabad-500046, Telangana**

---

23. In the event, any damage is caused to the movable or immovable property of the TIFR-Hyderabad or to the property of employees of the TIFR-Hyderabad, the TIFR-Hyderabad reserves the right to compute the damage in terms of money and to deduct the money from the bill of the contractor or from the amount payable to the contractor by the TIFR-Hyderabad and the remaining amount, if any, by the way of civil damages.
24. The contract is for providing maintenance services and not for supply of Contract Labour. The workers employed by the contractor for providing the services shall be of his/their employees and not of the TIFR-Hyderabad.
25. The personnel engaged by the contractor shall not have any employee-employer or master-servant relationship with the TIFR-Hyderabad and they shall not have any claim whatsoever for employment in the TIFR-Hyderabad now or at a future date.
26. The contractor shall remove his personnel peacefully on expiry of contract or on termination of the contract.
27. The contractor shall not sub-contract the works unless permitted specifically by the TIFR-Hyderabad in writing.
28. The contractor shall submit the bills in the first week of every month along with monthly report for the works carried out in the previous month. The TIFR-Hyderabad shall pay AMC charges on monthly basis upon submission of bills by the contractor and certified by the concerned employee/official to the effect that the maintenance works have been carried out as per the contract. Applicable TDS will be deducted while making the payment.
29. **The contractor should submit the wage bill/invoice for reimbursement as per details/table given below on his letter head latest by 10<sup>th</sup> of following month:-**
  - a. Bill No. \_\_\_\_\_ Date \_\_\_\_\_
  - b. Name of the company:
  - c. Contract for \_\_\_\_\_
  - d. Award letter Number & Date:
  - e. Date of commencement of the contract:
  - f. Wage bill for the month \_\_\_\_\_ date \_\_\_\_\_

**TATA INSTITUTE OF FUNDAMENTAL RESEARCH**  
**Survey No.36/P, Gopanpally Village, Serilingampally Mandal**  
**Ranga Reddy District, Hyderabad-500046, Telangana**

Sl. No.	Name of worker	Emp l Code No.	EP F No.	ES I No.	@ Basic Minimum Wage As per GOI (C)	No. of days worked	Total Wage	Employee's contribution		Take home Salary	Employer's contribution		
								EPF	ESI		EPF	EDL	ESI
								12 %	1.75 %		12 %	1 %	4.75 %

**Note:** Deduction Schedule showing the individual details of deductions of EPF and ESI should tally with the wage bill.

30. GST rule will be applicable with effect from 01.07.2017. The applicable TDS /other charges if any as per GST rule will be deducted as per new GST regime.
31. TIFR-Hyderabad GST NO: 36AAATT3951F2ZG.
32. The contractor should provide mobile telephone on site for communicating 24 x 7 basis duty personnel.
33. The contractor shall execute the agreement related to this contract on stamp paper as per proforma prescribed by the TIFR-Hyderabad.
34. The contractor shall pay the minimum monthly wages (Central) fixed by the Chief Labour Commissioner (Central), Delhi, Govt. of India, Ministry of Labour & Employment under the Minimum Wages Act as applicable in Hyderabad.
35. Enhancement in Administrative/Service charges, on any ground will not be entertained during the tenure of the contract for this intended period.
36. The contract can be terminated on any of the following contingencies:
  - On expiry of the contract period.
  - By giving one month advance notice by TIFR on account of:  
Un Satisfactory performance of the contract (as per tender terms and conditions).
37. Losses suffered by TIFR due to lapse on the part of the contractor/his Supervisor/workers.
  - i) For committing breach by the contractor of any of the terms and conditions of Contract.
  - ii) On assigning the contractor or any part thereof or any benefit or interest therein or there under by the contractor to any third person for sub-contracting whole or part of the contract.
  - iii) On violation of any Labour laws as per Contract Labour (Regulation & Abolition) Act, 1970, as amended from time to time.
  - iv) On contractors being declared insolvent by the competent Court of Law.

**TATA INSTITUTE OF FUNDAMENTAL RESEARCH**  
**Survey No.36/P, Gopanpally Village, Serilingampally Mandal**  
**Ranga Reddy District, Hyderabad-500046, Telangana**

---

- v) The contractor provides unsatisfactory services.
38. During the notice period of termination of the contract in the contingencies contemplated above, the contractor shall keep on discharging his duties as before till the expiry of notice period.
39. It shall be the duty of the contractor to withdraw all the persons deployed by him on expiry/termination of the contract and will ensure that no person creates any disruption/hindrance or problems of whatsoever nature to TIFR.
40. Income Tax will be recovered from the contractor's monthly bill as per the Govt. of India's order and necessary TDS certificate will be issued to him as a proof of having deducted the tax.
41. All disputes arising from this contract in respect of personnel posted at TIFR concerning their wages or any other matter connected with their service conditions under relevant Labour Laws are solely and wholly the responsibility of the Contractor. The TIFR will be free from all encumbrances either from the Government or from any other sources.
42. TIFR Hyderabad GST NO is: 36AAATT3951F2ZG. GST rule will be applicable with effect from 01.07.2017 as per GST regime. The applicable TDS /other charges if any as per GST rule will be deducted.
43. The contractor should submit a valid GST Registration document / certificate etc. The TIFR will pay Goods and Services Tax (GST), as applicable on the bill submitted by the contractor.
44. That the contractor shall ensure that the persons so deployed do not allow any property of the TIFR to be taken out of the premises without a Gate Pass signed by the designated officials of the Institute. As a safeguard against any dishonesty connivance and/or ulterior motive, the specimen signature of the officials designated and authorized to sign the gate pass will be intimated in writing to the contractor along with subsequent changes, if any. The Administrative Officer of TIFR shall take necessary steps to ensure compliance and necessary action in this respect.
45. All the bills should be submitted on his letter heads, duly signed and pre-receipted.
46. **ARBITRATION**
- A. In the event of any question, dispute/difference arising under the agreement or in connection herewith (except as to matters the decision of which is especially provided under this agreement) the same shall be referred to the sole arbitration to Centre Director TIFR, Hyderabad or his nominee.
- B. The award of the arbitrator shall be final and binding on their parties. In the event of such arbitrator to whom the matter is originally referred is being transferred or vacating his office or resigning or refusing to work or neglecting his work or being unable to act for any reason whatsoever, the TIFR shall appoint another person to act as arbitrator in place of the out-going arbitrator in accordance with the terms of this agreement and the persons so appointed shall be entitled to proceed with the reference from the stage at which it was left by his predecessor.

**TATA INSTITUTE OF FUNDAMENTAL RESEARCH**  
**Survey No.36/P, Gopanpally Village, Serilingampally Mandal**  
**Ranga Reddy District, Hyderabad-500046, Telangana**

---

- C. The Arbitrator may give interim award(s) and/or directions, as may be required.
- D. Subject to the aforesaid provisions, the Arbitration & Conciliation Act, 1996 and the rules made hereunder and any modifications are there of from time to time being in force shall be deemed to apply to the arbitration proceedings under this clause.

**Date:**

**(Name & signature of the contractor with office seal)**

**SPECIAL CONDITIONS OF CONTRACT**

**1. Engagement terms of labour:**

- i. The agreement between TIFR-Hyderabad and the contractor shall be purely on the basis of service agreement. The Contractor shall make his own arrangements for the engagement of the labour.
- ii. In respect of the engagement, employment, wages, transport, paying, feeding, housing and working conditions of labor and of all matters connected therewith, the contractor shall be solely responsible and liable.
- iii. During the continuance of the Contract, the contractor shall at all times be liable to obligations imposed on him by the provisions and requirements of any Central or State Statute ordinance or other law or any Regulation or Bye-law of any local or other duly constituted authority which may be applicable including any such law regulation or order passed or made or coming into force during the period of the Contract.
- iv. The Contractor shall comply with the provision of all labour legislation including the requirements of:
  - a) The payment of Wages Act
  - b) Owner's Liability Act
  - c) Workmen's Compensation Act
  - d) Contractor Labour (Regulation & Abolition) Act 1970 and Central Rules 1971
  - e) Apprentices Act 1961
  - f) Any other Act or enactment relating thereto and rules framed thereunder from time to time.
- v. The successful tenderer shall keep all mandatory records like PF, ESI, Bonus etc. of his employees deployed at TIFR-Hyderabad, Survey No. 36/P, Gopanpally(Village), Serilingampally Mandal, RR Dist, Hyderabad-500046 as per requirement of the labour enforcement inspector from time to time.
- vi. The successful tenderer shall take necessary license from the Asst. Labour Commissioner and comply with the central Labour Act of 1970.
- vii. The successful tenderer shall have to take necessary insurance coverage for his workmen and keep TIFR-Hyderabad indemnified against risk. Copy of such insurance premium receipt shall be submitted to TIFR-Hyderabad before the release of first payment.

**2. Accidents:**

The Contractor shall within 24 hours of the occurrence of any accident or mishap at or about the Site or in connection with the execution of the work shall report such incident to TIFR-Hyderabad. The Contractor shall also report such accident to the competent authority whenever such report is required by law.

**TATA INSTITUTE OF FUNDAMENTAL RESEARCH**  
**Survey No.36/P, Gopanpally Village, Serilingampally Mandal**  
**Ranga Reddy District, Hyderabad-500046, Telangana**

---

**3. Insurance:**

Workman insurance policy in the joint name of TIFR-Hyderabad and the Bidder should be submitted to TIFR-Hyderabad before commencing the work. Contractors shall cover all the men and labour, deployed by him on this work under an adequate comprehensive contractor's all risk policy, to insure Workmen and third party insurance etc.

4. The work is to be carried out in occupied office and laboratory premises and hence the contract shall be governed by the rules of TIFR-Hyderabad regarding the working hours, supply & removal of materials etc. The contractor and their personnel shall not cause disturbance to the staff and research activities of TIFR-Hyderabad.
5. The contractor should make proper safety arrangements like safety belts and helmets, etc. for the persons working on site. Contractor shall provide individual identity card to each of his staff /worker as per the approval format. The identity card shall be carried and displayed by the person during his entire presence or working in the premises.
- 6. The Contractor is advised to submit the copies of the following documents within 7 days from the date of acceptance of the contract to commence the work at TIFR Hyderabad.**
  - a. Labour License
  - b. Professional Tax Registration
  - c. Local ESI Registration
  - d. PF Registration
  - e. Workmen Compensation Policy
- 7. If the contractor fails to submit the documents mentioned in clause 6, the contract will be stand cancelled and EMD will be forfeited.**

\* \* \* \* \*

**APPENDIX TO FORM OF TENDER**

a)	Minimum amount to third party insurance	The successful tenderer shall take “all risk policy” for the contract value and workmen compensation policy for the workers engaged in the work. The contractor shall indemnify the TIFR-Hyderabad for any loss or damage that occurs to persons or building or third party while executing the work. Third party liability in contractors all risk policy shall be minimum Rs. 2 lakh per person for any one accident or occurrence and 5.00 lakh in respect of damage to property for any one accident or occurrence. Note :These policies shall be valid till the completion of the work. If the contractor does not provide these policies, TIFR-Hyderabad reserves the right to take the above insurance policies themselves and recover the cost thereof from the bill/s of the contractor.
b)	Period of commencement	7 (Seven) days from the date of issue of letter of intent/work order or date of handing over of site, whichever is later.
c)	Period of Contract	12 months
d)	EMD to be deposited	Rs.40,600/-
e)	Security Deposit	10% of order value or Bank Guarantee of same value. EMD of successful tenderer will be adjusted against this money.

**PART-II**  
**PRICE BID**

**Annual Maintenance Contract for deploying Manpower for Plumbing/Carpentry Works/Operation & Maintenance of STP at TIFR, Survey No. 36/P, Gopanpally (Village), Serilingampally(Mandal), RR Dist, Hyderabad-500046.**

NAME OF THE TENDERER: -----

ADDRESS: -----  
-----  
-----  
-----

Last date of submission of the tender: On or before 09.09.2020 by 13:00hrs.



**TATA INSTITUTE OF FUNDAMENTAL RESEARCH**  
**Survey No.36/P, Gopanpally Village, Serilingampally Mandal**  
**Ranga Reddy District, Hyderabad-500046, Telangana**

**I. Wages stipulated by TIFR**

<b>Sub Head A</b>			
<b>Wages Calculation Sheet for Plumbing,Stp,Carpenter per Year</b>			
<b>MINIMUM WAGES</b>		<b>PLUMBING + STP</b>	<b>CARPENTER</b>
<b>Sr. No.</b>	<b>Payment Components</b>	<b>Skilled Category</b>	<b>Skilled Category</b>
		<b>Per Head (in Rs.)</b>	<b>Per Head (in Rs.)</b>
1	Basic Wages	16562.00	16562.00
2	Variable Dearness Allowance	3302.00	3302.00
<b>3</b>	<b>Sub Total</b>	<b>19864.00</b>	<b>19864.00</b>
4	Leave Wages @ 4.81% on S.No 3	955.46	955.46
5	PF @ 13.00% on S.No 3	2582.32	2582.32
6	ESI @ 3.25 % on S.No 3	645.58	645.58
7	Bonus @ 8.33% on S.No 3	1654.67	1654.67
<b>8</b>	<b>Total Sr. No. (3 to 7) including statutory payments</b>	<b>25702.03</b>	<b>25702.03</b>
9	No. of personnel deployed	3.00	1.00
<b>10</b>	<b>Total minimum charges for proposed deployment</b>	<b>77106.09</b>	<b>25702.03</b>
11	Reliever Charges in Rs.1/6th of Sr. No.10	12851.01	0.00
<b>12</b>	<b>Total Minimum Wages for personnel deployed per month</b>	<b>89957.10</b>	<b>25702.03</b>
<b>13</b>	Service Charges per month .....% on Sr. No. 12		
<b>14</b>	<b>Total Sr. No. (12+13) per month</b>		
<b>15</b>	<b>Total Per Year</b>		
16	GST per month 18%		
<b>17</b>	<b>TOTAL FOR STP, PLUMBING &amp; CARPENTRY WORKS</b>		
<b>18</b>	<b>GRAND TOTAL FOR STP, PLUMBING &amp; CARPENTRY WORKS</b>		
		<b>Grand Total A</b>	

**TATA INSTITUTE OF FUNDAMENTAL RESEARCH**  
**Survey No.36/P, Gopanpally Village, Serilingampally Mandal**  
**Ranga Reddy District, Hyderabad-500046, Telangana**

<b>Sub head-B</b>		
<b>1</b>	Charges for testing of input and output water in a qualified Lab and certified by qualified engineer/consultant.(Rates per month)	
<b>2</b>	Visit of expert(Must be of B.Tech,Environment/M.Tech,Environment) per month to verify the Health condition of plant	
<b>3</b>	Total charges per month	
<b>4</b>	Total charges per Year	
<b>5</b>	Gst @ 18%	
<b>Grand Total B (Sl. 4 + Sl. 5)</b>		

<b>Sub head-C</b>		
<b>1</b>	Supply of Sodium hypochloride (Commercial Grade of 10-12% strength,Payments to be made as per actual )40 kg /month	
<b>2</b>	Total charges per Year	
<b>3</b>	Gst @ 18%	
<b>Grand Total C (Sl. 2+ Sl. 3)</b>		

<b><u>GRAND TOTAL (A+B+C)</u></b>	
<b><u>In Words:</u></b>	

**NOTE:**

- a. The contractor shall make the payment to personnel engaged by him as per minimum wages notified by Office of the Regional Labour Commissioner (Central) and any revision in the wages during the period of contract.
- b. The quoted rates shall be inclusive of all applicable statutory payments viz. Minimum Wages(**including revisions**), PF, ESI, Gratuity, Bonus and necessary risk policy for covering the comprehensive risk of all employees etc.
- c. The contractor shall provide minimum one-day duty off once in a week for the employees working in shifts and shall provide relievers for the employees on off duty / sick / leave.
- d. Conditional tenders shall be summarily rejected.
- e. Please note that **final bid amount** will be considered for evaluation of tenders.
- f. The contractors are advised to visit the site and thoroughly understand the nature and scope of work and be familiar with the site conditions before quoting.

Contractors Signature & Seal

**TATA INSTITUTE OF FUNDAMENTAL RESEARCH**  
**Survey No.36/P, Gopanpally Village, Serilingampally Mandal**  
**Ranga Reddy District, Hyderabad-500046, Telangana**

---

I/We have examined the scope of work and terms & conditions of the tender for the said works. If this tender is accepted by TIFR-Hyderabad, I/We hereby by agree to execute the works in accordance with terms and conditions of the tender.

Date:

(Signature and Name of the authorized person  
of the firm/contractor with office seal)