



टाटा मूलभूत अनुसंधान संस्थान
TATA INSTITUTE OF FUNDAMENTAL RESEARCH
भारत सरकार के परमाणु ऊर्जा विभाग की स्वायत्त संस्था एवं समविश्वविद्यालय
(An Autonomous Institute of the Department of Atomic Energy,
Government of India, and a Deemed University)
सर्वेक्षण संख्या 36 / पी, गोपनपल्ली गांव, सेरिलिंगमपल्ली मंडल, रंगारेड्डी जिला, हैदराबाद - 500 046
36/P, Gopanpally Village, Serilingampally Mandal, Ranga Reddy District, Hyderabad - 500 046

Telephone:+91-40-20203009	Date:27.08.2024
Website : www.tifrh.res.in	Email: krishnaae@tifrh.res.in

NOTICE INVITING TENDER

(TWO PART PUBLIC TENDER) for the following works:

Supply, Installation, Testing and commissioning of High side and Low side HVAC works for Animal Facility in Hanger-02, TIFR, Survey No. 36/P, Gopanpally (Village), Serilingampally (Mandal), Ranga Reddy Dist., Hyderabad-500046.	
निविदा सं. Tender No.	TIFR/PD/CA24-50/240633
निविदा का प्रकार Type of Tender	Two Part Tender (Part-I: Technical Bid and Part- II: Price Bid)
अनुमानित लागत Estimated Cost	Rs.42,56,741/-
ईएमडी की लागत Cost of EMD	Rs.85,135/-(डिमांड ड्राफ्ट "टीआईएफआर सेंटर फॉर इंटरडिसिप्लिनरी साइंसेस" के पक्ष में तैयार किया जाना है, जो हैदराबाद में देय है (तकनीकी बोली भाग - I के साथ संलग्न किया जाना है)।" Rs.85,135/-(Demand Draft to be drawn in favor of "TIFR Center for Interdisciplinary Sciences", Payable at Hyderabad (To be enclosed with the Technical Bid Part – I).
बोली पूर्व बैठक और समय Pre bidding meeting & Time	30.08.2024 at 11:00 Hrs
निविदा प्रस्तुत करने की अंतिम तिथि Last Date for Submission of Tender	05.09.2024 by 13:00 Hrs
बोली खोलने की तिथि (केवल भाग-I: तकनीकी बिड) Date of Opening Bids(Only Part-I: Technical Bid)	05.09.2024 at 15:00 Hrs

- "यदि भाग "I" और भाग "II" बोलियों को अलग-अलग लिफाफों में सील नहीं किया जाता है तो निविदा को अस्वीकार कर दिया जाएगा।"
- In case the Part "I" and Part "II" bids are not sealed in separate envelopes the tender will be rejected.
- तकनीकी बोली में मूल्य का कोई संकेत नहीं होना चाहिए।
The technical bid should not contain any indication of the price.
- निविदा शुल्क और ईएमडी के भुगतान के बिना प्राप्त तकनीकी बोली को सरसरी तौर पर अस्वीकार कर दिया जाएगा। The Technical Bid received without EMD shall be summarily rejected.



टाटा मूलभूत अनुसंधान संस्थान
TATA INSTITUTE OF FUNDAMENTAL RESEARCH
भारत सरकार के परमाणु ऊर्जा विभाग की स्वायत्त संस्था एवं समविश्वविद्यालय
(An Autonomous Institute of the Department of Atomic Energy,
Government of India, and a Deemed University)

सर्वेक्षण संख्या 36 / पी, गोपनपल्ली गांव, सेरिलिंगमपल्ली मंडल, रंगारेड्डी जिला, हैदराबाद - 500 046
36/P, Gopanpally Village, Serilingampally Mandal, Ranga Reddy District, Hyderabad - 500 046

संपर्क: श्री कृष्ण, दूरभाष: 040- 20203009 किसी भी तकनीकी या वाणिज्यिक शर्तों के लिए निविदा में उल्लिखित स्पष्टीकरण Contacts: Mr. Krishna, Tel: 040- 20203009 for any technical or commercial terms clarifications mentioned in the tender.

Sealed tenders are invited for the aforesaid works from contractors having similar work experience in reputed Research Institutions, Universities, Central Government/Public Sector Undertaking, Private Laboratories, Multinational Companies, etc. Interested contractors who are satisfying prequalification criteria stipulated by TIFR-Hyderabad shall only submit their bids. For further details and any clarification on the tender you may please contact Head-Technical Services, Survey No.36/P, Gopanpally Village, Serilingampally Mandal, Ranga Reddy District, Hyderabad-500046.

Last date for submission of the tender is 05.09.2024 by 13:00 Hrs.

(Rajasekhar. R)

Head-Technical Services



टाटा मूलभूत अनुसंधान संस्थान
TATA INSTITUTE OF FUNDAMENTAL RESEARCH
भारत सरकार के परमाणु ऊर्जा विभाग की स्वायत्त संस्था एवं समविश्वविद्यालय
(An Autonomous Institute of the Department of Atomic Energy,
Government of India, and a Deemed University)
सर्वेक्षण संख्या 36 / पी, गोपनपल्ली गांव, सेरिलिंगमपल्ली मंडल, रंगारेड्डी जिला, हैदराबाद - 500 046
36/P, Gopanpally Village, Serilingampally Mandal, Ranga Reddy District, Hyderabad - 500 046

TENDER DOCUMENT

Supply, Installation, Testing and commissioning of High side and Low side HVAC works for Animal Facility in Hanger-02, TIFR, Survey No. 36/P, Gopanpally (Village), Serilingampally (Mandal), Ranga Reddy Dist., Hyderabad-500046.

Name of the Tenderer:.....

Address:

.....

.....

.....

Last date of submission of the tender: On or before 05.09.2024 by 13:00 Hrs



टाटा मूलभूत अनुसंधान संस्थान
TATA INSTITUTE OF FUNDAMENTAL RESEARCH
भारत सरकार के परमाणु ऊर्जा विभाग की स्वायत्त संस्था एवं समविश्वविद्यालय
(An Autonomous Institute of the Department of Atomic Energy,
Government of India, and a Deemed University)

सर्वेक्षण संख्या 36 / पी, गोपनपल्ली गांव, सेरिलिंगमपल्ली मंडल, रंगारेड्डी जिला, हैदराबाद - 500 046
36/P, Gopanpally Village, Serilingampally Mandal, Ranga Reddy District, Hyderabad - 500 046

TECHNICAL BID

VOLUME-I

Supply, Installation, Testing and commissioning of High side and Low side HVAC works for Animal Facility in Hanger-02, TIFR, Survey No. 36/P, Gopanpally (Village), Serilingampally (Mandal), Ranga Reddy Dist., Hyderabad-500046.



टाटा मूलभूत अनुसंधान संस्थान
TATA INSTITUTE OF FUNDAMENTAL RESEARCH
भारत सरकार के परमाणु ऊर्जा विभाग की स्वायत्त संस्था एवं समविश्वविद्यालय
(An Autonomous Institute of the Department of Atomic Energy,
Government of India, and a Deemed University)

सर्वेक्षण संख्या 36 / पी, गोपनपल्ली गांव, सेरिलिंगमपल्ली मंडल, रंगारेड्डी जिला, हैदराबाद - 500 046
36/P, Gopanpally Village, Serilingampally Mandal, Ranga Reddy District, Hyderabad - 500 046

Tender Notice	:	TIFR/PD/CA24-50/240633
Name of Work	:	Supply, Installation, Testing and commissioning of High side and Low side HVAC works for Animal Facility in Hanger-02, TIFR, Survey No. 36/P, Gopanpally (Village), Serilingampally (Mandal), Ranga Reddy Dist., Hyderabad-500046.
Location	:	Tata Institute of Fundamental Research Survey No. 36/P, Gopanpally village, Serilingampally Mandal, Ranga Reddy District, Hyderabad – 500046.
Estimated Cost	:	Rs.42,56,741/-
EMD	:	Rs.85,135/- (Demand Draft to be drawn in favor of “TIFR Center for Interdisciplinary Sciences”, Payable at Hyderabad (To be enclosed with the Technical Bid Part – I).
Delivery Period	:	90 Days (Completion Period)
Validity	:	Seventy Five (75) days after opening of Part-I, Technical Bid



टाटा मूलभूत अनुसंधान संस्थान
TATA INSTITUTE OF FUNDAMENTAL RESEARCH
भारत सरकार के परमाणु ऊर्जा विभाग की स्वायत्त संस्था एवं समविश्वविद्यालय
(An Autonomous Institute of the Department of Atomic Energy,
Government of India, and a Deemed University)

सर्वेक्षण संख्या 36 / पी, गोपनपल्ली गांव, सेरिलिंगमपल्ली मंडल, रंगारेड्डी जिला, हैदराबाद - 500 046
36/P, Gopanpally Village, Serilingampally Mandal, Ranga Reddy District, Hyderabad - 500 046

INDEX

SECTION	DESCRIPTION	PAGE NO.
SECTION I	IMPORTANT INFORMATION	7-9
SECTION II	ELIGIBILITY CRITERIA FOR QUALIFICATION OF TENDER	10-17
SECTION III	NOTICE & INSTRUCTIONS	18-22
SECTION IV	GENERAL INFORMATION	24-33
SECTION V	TECHNICAL SPECIFICATIONS	34-44
SECTION VI	ANNEXURES	45-58
SECTION VII	FINANCIAL BID (PART II)	59-67



टाटा मूलभूत अनुसंधान संस्थान
TATA INSTITUTE OF FUNDAMENTAL RESEARCH
भारत सरकार के परमाणु ऊर्जा विभाग की स्वायत्त संस्था एवं समविश्वविद्यालय
(An Autonomous Institute of the Department of Atomic Energy,
Government of India, and a Deemed University)

सर्वेक्षण संख्या 36 / पी, गोपनपल्ली गांव, सेरिलिंगमपल्ली मंडल, रंगारेड्डी जिला, हैदराबाद - 500 046
36/P, Gopanpally Village, Serilingampally Mandal, Ranga Reddy District, Hyderabad - 500 046

SECTION-I

IMPORTANT INFORMATION

INTRODUCTION

The Tata Institute of Fundamental Research is a National Centre of the Government of India, under the umbrella of the Department of Atomic Energy, as well as a deemed University awarding degrees for master's and doctoral programs. Tata Institute of Fundamental Research Centre for Interdisciplinary Sciences, Hyderabad invites bids for the following work:

Supply, Installation, Testing and Commissioning of High side and Low side HVAC works for Animal Facility in Hanger-02, TIFR, Survey No. 36/P, Gopanpally (Village), Serilingampally (Mandal), Ranga Reddy Dist., Hyderabad-500046.

1. PARTICULARS

a)	Location	TIFR, Survey No. 36/P, Gopanpally (Village), Serilingampally (Mandal), Ranga Reddy Dist., Hyderabad-500046.
b)	Pre-Bid Meeting Date & Time	30.08.2024 at 11:00 Hrs
c)	Closing date & time of receipt of bids	05.09.2024 by 13:00 Hrs
d)	Date & time of opening of Sealed Cover-I containing Technical Bid	05.09.2024 at 15:00 Hrs
e)	Date of opening of Sealed cover-II containing Financial of eligible bidders	To be intimated to eligible bidders subsequently which is likely to be within 7 days after opening of Technical Bid

2. GENERAL INSTRUCTIONS

- 2.1. TIFR shall award the contract for the project through the two Bid systems.
- 2.2. The Contractor is advised to visit and examine the site of work and its surroundings and obtain any information that may be necessary, in addition to those provided in this document. The Contractor shall be deemed to have fully acquainted himself about the site condition, whether he inspects it or not.
- 2.3. The Contractor should adhere to the building bye-laws applicable for the area.
- 2.4. All clarifications shall be sought before the date of pre-bid meeting. The bidders may make suggestions which shall be considered during the Pre Bid Meeting. No further clarifications shall be issued after the issue of noteworthy replies to the pre-bid queries.
- 2.5. The submission of the bid by Contractor would imply that they have carefully read and agreed to the terms and conditions contained in this bid document.



टाटा मूलभूत अनुसंधान संस्थान
TATA INSTITUTE OF FUNDAMENTAL RESEARCH
भारत सरकार के परमाणु ऊर्जा विभाग की स्वायत्त संस्था एवं समविश्वविद्यालय
(An Autonomous Institute of the Department of Atomic Energy,
Government of India, and a Deemed University)

सर्वेक्षण संख्या 36 / पी, गोपनपल्ली गांव, सेरिलिंगमपल्ली मंडल, रंगारेड्डी जिला, हैदराबाद - 500 046
36/P, Gopanpally Village, Serilingampally Mandal, Ranga Reddy District, Hyderabad - 500 046

- 2.6. The bid for the work shall remain open for acceptance for a period of 75(seventy five) days from the date of submission of the bids, which period may be extended by mutual agreement and the Contractor shall not cancel or withdraw the offer during this period.
- 2.7. This bid document shall form a part of the contract agreement.

3. SUBMISSION OF BIDS

Bids shall be submitted to Head- Technical Services, **TIFR, Survey No. 36/P, Gopanpally (Village), Serilingampally (Mandal), Ranga Reddy Dist, Hyderabad-500046** in a sealed Master envelope super scribed "Bid for **Supply, Installation, Testing and commissioning of High side and Low side HVAC works for Animal Facility in Hanger-02, TIFR** with our enquiry no. and due date, containing two separate sealed covers clearly super scribed as "**Technical Bid**" and "**Financial Bid**" before the closing date and time of submission in the following manner:

- a) "**Technical Bid**": This will contain Technical part, Eligibility Documents along with testimonials. Earnest Money Deposit (EMD).
- b) "**Financial Bid**": This will contain the complete bidding document with duly filled in Schedule of Financial Quote of Financial Bid & Tender Drawings.

The Bids without signature of the authorized person of bidder and seal, without EMD, with conditions or conditional rebates shall be summarily rejected.

4. EVALUATION OF BID

- 4.1. **EVALUATION OF TECHNICAL BID**: The bids received will first be first opened and will be examined for EMD/ Declaration Letter, Eligibility Criteria, Conditions, etc. Conditional Tenders and Tenders without EMD/Declaration Letter shall be summarily rejected.
- 4.2. **EVALUATION OF FINANCIAL BID**: The Financial Bid should contain the complete bid document with duly filled in Schedule of Financial Quote of Financial Bid and signed Tender drawings. Financial Bids of Technically qualified Bidders will only be opened. Work will be awarded to lowest bidder (L1) based on their quotes after making necessary arithmetical checks.

5. SCOPE & OBJECTIVE

The Objective of the tender is to **Supply, Installation, Testing and commissioning of High side and Low side HVAC works for Animal Facility in Hanger-02, TIFR, Survey No. 36/P, Gopanpally (Village), Serilingampally (Mandal), Ranga Reddy Dist., Hyderabad-500046** as per the specifications and Bill of quantities mentioned in the Financial Bid.

Period of Completion of Work: 90 days from the date of issue of work order

Defect Liability Period: 12 months from the date of handing over of completed system as per tender.

6. PAYMENT SCHEDULE:

The contractor shall submit the bills for payments along with a detailed statement showing the actual works carried out under different heads of items in the format specified by the TIFR. Minimum value of the work for interim payment (**two Running Bill**) shall be 35% of the work order value. All interim and final bills will be settled based on the joint measurements of each item of work and certified by TIFR Engineer. The bills for



टाटा मूलभूत अनुसंधान संस्थान
TATA INSTITUTE OF FUNDAMENTAL RESEARCH
भारत सरकार के परमाणु ऊर्जा विभाग की स्वायत्त संस्था एवं समविश्वविद्यालय
**(An Autonomous Institute of the Department of Atomic Energy,
Government of India, and a Deemed University)**

सर्वेक्षण संख्या **36 / पी**, गोपनपल्ली गांव, सेरिलिंगमपल्ली मंडल, रंगारेड्डी जिला, हैदराबाद - **500 046**
36/P, Gopanpally Village, Serilingampally Mandal, Ranga Reddy District, Hyderabad - 500 046

nonperishable materials on site may also be submitted and the payment by TIFR against the same shall be to the maximum extent of 60% of the value of these materials on production of sufficient documentary evidence i.e. Original invoice, Inventory, etc. All interim bills will be paid within **30** days from the date of submission and Final Bill along with all relevant documents will be settled within **30** days from the date of submission with certification of TIFR Engineer.



टाटा मूलभूत अनुसंधान संस्थान
TATA INSTITUTE OF FUNDAMENTAL RESEARCH
भारत सरकार के परमाणु ऊर्जा विभाग की स्वायत्त संस्था एवं समविश्वविद्यालय
(An Autonomous Institute of the Department of Atomic Energy,
Government of India, and a Deemed University)

सर्वेक्षण संख्या 36 / पी, गोपनपल्ली गांव, सेरिलिंगमपल्ली मंडल, रंगारेड्डी जिला, हैदराबाद - 500 046
36/P, Gopanpally Village, Serilingampally Mandal, Ranga Reddy District, Hyderabad - 500 046

SECTION-II

ELIGIBILITY CRITERIA FOR TENDER QUALIFICATION

Supply, Installation, Testing and commissioning of High side and Low side HVAC works for Animal Facility in Hanger-02,TIFR, Survey No. 36/P, Gopanpally (Village), Serilingampally (Mandal), Ranga Reddy Dist., Hyderabad-500046.

● **Eligibility criteria:**

1. The Agencies/Contractors shall hold a valid labor license issued by appropriate authority and must be valid throughout the contractual period.
2. An Authorized dealer/Channel partner of chillers's manufacturers are only eligible.
3. IT Returns for the last three consecutive financial years ended on March 31, 2024 audited by CA.
4. The Agencies/Contractors should have an average annual turnover of **Rs.17** lakhs during three previous financial years ending March 31, 2024.
5. The Agencies/Contractors should have a latest solvency certificate issued by any nationalized bank of value not less than **Rs.17** Lakhs
6. The Agencies/Contractors should not have incurred any loss in more than two years during the immediate last five consecutive financial years, duly certified by the Chartered Accountant.
7. The Agencies/Contractors should have valid PAN from Income Tax Authority, GST registration No. etc. and any other registration applicable/mandatory for contract.
8. Submission of Technical Data Sheets as per Annexure-IV
9. The Agencies/Contractors should have executed similar installations of High side and low side HVAC works at least
 - 9.1. One similar work costing **Rs.34** Lakhs or
 - 9.2. Two similar works costing **Rs.25.5** Lakhs or
 - 9.3. Three similar works costing **Rs.17** Lakhs during the last 7 financial years ended on the end date of receiving tender for Research Institutes, Universities, Private Laboratories, R & D institutes, etc. in any Government /PSU/Private organizations of repute.

The value of executed works shall be brought to the current costing level by enhancing the actual value of work at a simple rate of 7% per annum calculated from the date of completion to the last date of receipt of applications for tender.

The Agencies/Contractors should furnish copies of work orders along with BOQ and completion certificates are mandated from the clients in support of the above.

Note:

- ❖ Agencies/Contractors are advised to inspect the site to understand the scope of work comprehensively before submission of tender.
- ❖ Agencies/Contractors should arrange the site inspection to TIFR officials for the qualifying works at their own cost if required.



टाटा मूलभूत अनुसंधान संस्थान
TATA INSTITUTE OF FUNDAMENTAL RESEARCH
भारत सरकार के परमाणु ऊर्जा विभाग की स्वायत्त संस्था एवं समविश्वविद्यालय
(An Autonomous Institute of the Department of Atomic Energy,
Government of India, and a Deemed University)

सर्वेक्षण संख्या 36 / पी, गोपनपल्ली गांव, सेरिलिंगमपल्ली मंडल, रंगारेड्डी जिला, हैदराबाद - 500 046
36/P, Gopanpally Village, Serilingampally Mandal, Ranga Reddy District, Hyderabad - 500 046

-
- ❖ Agencies/Contractors should have a full-fledged in-house project management team to undertake the jobs.
 - ❖ The Agencies/Contractors shall **strictly furnish** aforesaid information in the formats/schedules given. **Non adherence to furnishing of information in the given format/schedules given will lead to disqualification of tender.**
 - ❖ Instructions to Agencies/Contractors for furnishing the information is given as under:
 - Each page of the application shall be signed by a person having necessary authority to do so.
 - If the space in the proforma is insufficient for furnishing full details, such information may be given in separate sheets.
 - Applicants are required to furnish information against each item of the application. In case a certain item is not applicable, please write NA. Application containing incorrect and or inadequate information is liable to be rejected.



टाटा मूलभूत अनुसंधान संस्थान
TATA INSTITUTE OF FUNDAMENTAL RESEARCH
भारत सरकार के परमाणु ऊर्जा विभाग की स्वायत्त संस्था एवं समविश्वविद्यालय
(An Autonomous Institute of the Department of Atomic Energy,
Government of India, and a Deemed University)
सर्वेक्षण संख्या 36 / पी, गोपनपल्ली गांव, सेरिलिंगमपल्ली मंडल, रंगारेड्डी जिला, हैदराबाद - 500 046
36/P, Gopanpally Village, Serilingampally Mandal, Ranga Reddy District, Hyderabad - 500 046

SCHEDULE – A
BASIC INFORMATION

1. Name of the firm :
2. a) Address :
- b) Telephone / Fax No. :
- c) Mobile No. Contact Person :
- d) PAN No. :
- e) GST Registration No. :
- f) Labour License Details :
- Branch Office if any in Hyderabad :
3. Type of Organization (Proprietorships / Partnership) Ltd. Co. / Co-Operative) (Copy of relevant document to be enclosed) :
4. Date of Incorporation :
5. Nature of Business :
6. Experience as prime Agencies/ Contractors (in Yrs.) :
7. Name and address of Bankers :
8. Organization chart of the Company including names and positions of directors / key personnel :

Signature of the Applicant (s)



टाटा मूलभूत अनुसंधान संस्थान
TATA INSTITUTE OF FUNDAMENTAL RESEARCH
भारत सरकार के परमाणु ऊर्जा विभाग की स्वायत्त संस्था एवं समविश्वविद्यालय
(An Autonomous Institute of the Department of Atomic Energy,
Government of India, and a Deemed University)
सर्वेक्षण संख्या 36 / पी, गोपनपल्ली गांव, सेरिलिंगमपल्ली मंडल, रंगारेड्डी जिला, हैदराबाद - 500 046
36/P, Gopanpally Village, Serilingampally Mandal, Ranga Reddy District, Hyderabad - 500 046

SCHEDULE - B

High side and Low side HVAC works (Copies of the completion certificate to be enclosed)

A. Similar work of costing Rs.34 lakhs or two similar works of costing Rs.25.5 lakhs or 3 similar works of costing Rs.17 Lakhs during last 7 financial years ended on end date of receiving tender for Research Institutes, Universities, Private Laboratories, R & D institutes, etc

S r. N o	Name of the project & Address	Descr iption of work in brief	Name of the Engineer	Name of the client also indicate whether Govt or semi Govt or Pvt body with full postal address	Contract Amount in Rs.	Year of comme nceme nt	Date of Completion		Whether work was left /uncomplete d or the contract was terminated from either side? Give Details.	Any other relevant information
							Stipulated	Actual		
1.										
2.										

Contractor Signature & Stamp



टाटा मूलभूत अनुसंधान संस्थान
TATA INSTITUTE OF FUNDAMENTAL RESEARCH
भारत सरकार के परमाणु ऊर्जा विभाग की स्वायत्त संस्था एवं समविश्वविद्यालय
(An Autonomous Institute of the Department of Atomic Energy,
Government of India, and a Deemed University)
सर्वेक्षण संख्या 36 / पी, गोपनपल्ली गांव, सेरिंगम्पल्ली मंडल, रंगारेड्डी जिला, हैदराबाद - 500 046
36/P, Gopanpally Village, Serilingampally Mandal, Ranga Reddy District, Hyderabad - 500 046

B. List of works in progress above Rs.17 lakhs.

S No.	Name of the project & Address	Description of work in brief	Name of the Engineer with full postal address	Name of the Client. Also indicate whether Govt. or semi Govt. or Pvt. Body with full postal address	Contract Amount in (Rs.)	Date of Completion	Present stage of work with reasons if the work is getting delayed	Any other relevant information
1.								
2.								
3.								

Signature of the Applicant (s)

Contractor Signature & Stamp

14 Out of 67



टाटा मूलभूत अनुसंधान संस्थान
TATA INSTITUTE OF FUNDAMENTAL RESEARCH
भारत सरकार के परमाणु ऊर्जा विभाग की स्वायत्त संस्था एवं समविश्वविद्यालय
(An Autonomous Institute of the Department of Atomic Energy,
Government of India, and a Deemed University)
सर्वेक्षण संख्या 36 / पी, गोपनपल्ली गांव, सेरिलिंगमपल्ली मंडल, रंगारेड्डी जिला, हैदराबाद - 500 046
36/P, Gopanpally Village, Serilingampally Mandal, Ranga Reddy District, Hyderabad - 500 046

SCHEDULE – C

TECHNICAL PERSONNEL & SPECIAL EXPERIENCE

List of technical personnel in your establishment giving details about their technical qualification and experience

Sr No	Name	Age	Qualifications	Project Experience	Nature of works handled	Name of the project Handled	Date from which employed in your organization	Indicate special experience in Air Conditioners installation & Testing projects in which were employed
1								
2								

2. Indicate other points if any to show your technical and managerial competency to indicate any important point in your favor.

Signature of the Applicant(s)



टाटा मूलभूत अनुसंधान संस्थान
TATA INSTITUTE OF FUNDAMENTAL RESEARCH
भारत सरकार के परमाणु ऊर्जा विभाग की स्वायत्त संस्था एवं समविश्वविद्यालय
(An Autonomous Institute of the Department of Atomic Energy,
Government of India, and a Deemed University)
सर्वेक्षण संख्या 36 / पी, गोपनपल्ली गांव, सेरिलिंगमपल्ली मंडल, रंगारेड्डी जिला, हैदराबाद - 500 046
36/P, Gopanpally Village, Serilingampally Mandal, Ranga Reddy District, Hyderabad - 500 046

SCHEDULE – D

FINANCIAL POSITION AND WORKING RESULTS

	2021-22	2022-23	2023-24
1. Annual turnover	:	Rs.	
2. Net Profit	:	Rs.	
3. Credit Facilities from the Bank	:	Rs.	
a) Cash Credit	:	Rs.	
b) Overdraft Limit	:	Rs.	
c) Guarantee	:	Rs.	
d) Others	:	Rs.	
4. Certificate from the Bankers regarding financial soundness of the applicant	:	Enclosed (Yes / No)	
5. Solvency Certificate from the Bankers	:	Enclosed (Yes / No)	

Signature of the Application (s)



टाटा मूलभूत अनुसंधान संस्थान
TATA INSTITUTE OF FUNDAMENTAL RESEARCH
भारत सरकार के परमाणु ऊर्जा विभाग की स्वायत्त संस्था एवं समविश्वविद्यालय
(An Autonomous Institute of the Department of Atomic Energy,
Government of India, and a Deemed University)
सर्वेक्षण संख्या 36 / पी, गोपनपल्ली गांव, सेरिलिंगमपल्ली मंडल, रंगारेड्डी जिला, हैदराबाद - 500 046
36/P, Gopanpally Village, Serilingampally Mandal, Ranga Reddy District, Hyderabad - 500 046

SCHEDULE – E

MISCELLANEOUS INFORMATION

- 1 Whether it would be possible to process Bank :
Guarantee for various advances
during execution of the work.
- 2 Details of Civil Suits / Litigations arose during :
execution of the contracts in the last 5 years.
- 3 Latest Income Tax Clearance Certificate :
- 4 Name of the two senior official of Organizations :
preferably Govt./Semi Govt/ Autonomous/ Public
Sector Organization for whom you have
executed important and major HVAC High side
and Low side works, who may be directly
contracted by TIFR to gather information about
your ability, competence and capacity of your
work/organization/etc.
- 5 Number of Supplementary sheets attached. :

Signature of the Applicant



टाटा मूलभूत अनुसंधान संस्थान
TATA INSTITUTE OF FUNDAMENTAL RESEARCH
भारत सरकार के परमाणु ऊर्जा विभाग की स्वायत्त संस्था एवं समविश्वविद्यालय
(An Autonomous Institute of the Department of Atomic Energy,
Government of India, and a Deemed University)

सर्वेक्षण संख्या 36 / पी, गोपनपल्ली गांव, सेरिलिंगमपल्ली मंडल, रंगारेड्डी जिला, हैदराबाद - 500 046
36/P, Gopanpally Village, Serilingampally Mandal, Ranga Reddy District, Hyderabad - 500 046

SECTION-III

NOTICE & INSTRUCTIONS

1. **Sealed item rate tenders** in the prescribed form are invited from Head-Technical Services, Tata Institute of Fundamental Research, Centre for Interdisciplinary Services, Hyderabad, for the following:

Tender Notice No.	TIFR/PD/CA24-50/240633
Name of Work	Supply, Installation, Testing and commissioning of High side and Low side HVAC works for Animal Facility in Hanger-02, TIFR, Survey No. 36/P, Gopanpally (Village), Serilingampally (Mandal), Ranga Reddy Dist., Hyderabad-500046.
Estimated Cost	Rs.42,56,741/-
Time Limit	90 days (Completion Period)
Earnest Money Deposit	Rs.85,135/- (Demand Draft to be drawn in favor of "TIFR Centre for Interdisciplinary Sciences "Payable at Hyderabad (To be enclosed with the Technical Bid Part -I)).
Last Date & Time of Submission of Tender	05.09.2024 by 13:00 Hrs
Date & Time of Opening of Technical Bid	05.09.2024 at 15:00 Hrs

2. **Submission of Tender & Opening:**

Tenders shall be submitted in a sealed envelope super scribed with Tender enquiry No., Due Date and with heading as "**Supply, Installation, Testing and commissioning of High side and Low side HVAC works for Animal Facility in Hanger-02,, TIFR, Survey No. 36/P, Gopanpally (Village), Serilingampally (Mandal), Ranga Reddy Dist., Hyderabad-500046.**" containing two separate sealed covers clearly super scribed as "TECHNICAL BID" and "FINANCIAL BID" on or before the closing date and time of submission in the following manner:

"**TECHNICAL BID**": This will contain the following:

- Proof of Tender Cost paid already
- Earnest Money Deposit as stipulated
- Schedules giving information on Eligibility Criteria with supporting documents specified for tender qualification.



टाटा मूलभूत अनुसंधान संस्थान
TATA INSTITUTE OF FUNDAMENTAL RESEARCH
भारत सरकार के परमाणु ऊर्जा विभाग की स्वायत्त संस्था एवं समविश्वविद्यालय
(An Autonomous Institute of the Department of Atomic Energy,
Government of India, and a Deemed University)

सर्वेक्षण संख्या 36 / पी, गोपनपल्ली गांव, सेरिलिंगमपल्ली मंडल, रंगारेड्डी जिला, हैदराबाद - 500 046
36/P, Gopanpally Village, Serilingampally Mandal, Ranga Reddy District, Hyderabad - 500 046

“FINANCIAL BID”: Signed copy of the Financial Bid quoting amount in the stipulated format and signed copies of the tender drawings.

3. Earnest Money Deposit (EMD): EMD shall be submitted in the form of Demand Draft / Pay Order / Banker's cheque issued by a Scheduled Bank, drawn in favor of **“TIFR Center for Interdisciplinary Sciences”**, (To be enclosed with the Technical Bid (Part-I))

Earnest Money Deposit (EMD): Every Bidder has to pay EMD of amount as specified elsewhere in this tender by Demand Draft in favor of **“TIFR Center for Interdisciplinary Sciences”** along with the offer. Quotations received without EMD shall be rejected and no correspondence whatsoever will be entertained. For successful bidders the EMD will be adjusted against Performance Guarantee and will be refunded after completion of work /supply of material at site and for unsuccessful bidders EMD will be refunded after placing the order to successful bidder.

4. Performance guarantee

The tenderer, whose tender is accepted, will be required to furnish a performance guarantee of 2.5% of the tendered amount within 7 (seven) working days from the date of intimation. This guarantee shall be in the form Demand Draft / Pay Order / Banker's cheque / Deposit or Government Securities / Fixed Deposit Receipt (FDR) or Guarantee Bonds (BG) of any Scheduled Bank in accordance with the form as Annexure – I hereto. In case a fixed deposit receipt of any Bank is furnished by the contractor to TIFR as part of the performance guarantee and the Bank is unable to make payment against the said fixed deposit receipt, the loss caused thereby shall fall on the contractor and the contractor shall forthwith on demand furnish additional security to TIFR to make good the deficit.

The Performance Guarantee shall be initially valid up to the stipulated date of completion **plus 60 days** beyond that. In case the time for completion of work gets enlarged, the contractor shall get the validity of performance Guarantee extended to cover such enlarged time for completion of work. The performance guarantee shall be returned to the contractor, without any interest, after recording of the completion certificate for the work by the competent authority.

The Engineer-in-charge shall make a claim under the Performance guarantee for amounts to which TIFR entitled under the contract (notwithstanding and / or without prejudice to any other provisions in the contract agreement) in the event of:

- a) Failure to attend and rectify the problems in the guarantee period, in which event the Engineer-in-charge may claim the full amount of the Performance guarantee.
- b) Failure by the contractor to pay TIFR, Hyderabad any amount due, either as agreed by the contractor or determined under any of the Clauses / Conditions of the agreement, within 30 days of the service of notice to this effect by Engineer-in-charge.



टाटा मूलभूत अनुसंधान संस्थान
TATA INSTITUTE OF FUNDAMENTAL RESEARCH
भारत सरकार के परमाणु ऊर्जा विभाग की स्वायत्त संस्था एवं समविश्वविद्यालय
**(An Autonomous Institute of the Department of Atomic Energy,
Government of India, and a Deemed University)**

सर्वेक्षण संख्या 36 / पी, गोपनपल्ली गांव, सेरिलिंगमपल्ली मंडल, रंगारेड्डी जिला, हैदराबाद - 500 046
36/P, Gopanpally Village, Serilingampally Mandal, Ranga Reddy District, Hyderabad - 500 046

In the event of the contract being determined under provisions of any of the relevant clauses of the agreement, the performance guarantee shall stand forfeited in full and shall be absolutely at the disposal of TIFR, Hyderabad.

5.Security Deposit: The tenderer, whose tender is accepted, will also be required to furnish by way of Security Deposit for fulfillment of his contract, an amount equal to 5% of the tendered value of the work. Earnest Money deposited at the time of tenders will be treated as part of the Security Deposit.

In case a fixed deposit receipt of any bank is furnished by the contractor to TIFR, Hyderabad as part of the security deposit and the bank is unable to make payment against the said fixed deposit receipt, the loss caused thereby shall fall on the contractor and the contractor shall forthwith on demand furnish additional security to TIFR, Hyderabad to make good the deficit.

All compensation or the other sums of money payable by the contractor under the terms of this contract may be deducted from, or paid by the sale of a sufficient part of his security deposit or from the interest arising there from, or from any sums which may be due to or may become due to the contractor by TIFR or any account whatsoever and in the event of his Security Deposit being reduced by reason of any such deductions or sale as aforesaid, the contractor shall within 10 days make good in cash or fixed deposit receipt tendered by the State Bank of India or by scheduled banks (if deposited for more than 12 months) endorsed in favor of the TIFR, HYDERABAD, any sum or sums which may have been deducted from, or raised by sale of his security deposit or any part thereof.

Security Deposit shall be initially valid up to one year from the date of completion of work. In case the time for completion of work gets enlarged, the contractor shall get the validity of Security Deposit extended to cover such enlarged time for completion of work. The Security Deposit shall be returned to the contractor, without any interest, after completion of defect liability period.

Security Deposit as deducted above can be released against Bank Guarantee issued by a Scheduled Bank on its accumulation to a minimum of Rs.5 Lakhs subject to the condition that amount of such Bank Guarantee, except last one, shall not be less than Rs.5 Lakhs. Bank Guarantee should be submitted which will be valid upto the expiry of defect liability period.

6.Acceptance of Tender: The competent authority, on behalf of TIFR, Hyderabad does not bind itself to accept the lowest or any other tender, and reserves to himself the authority to reject any or all the tenders received, without assignment of any reason. All tenders, in which any of the prescribed conditions is not fulfilled or any condition, including that of conditional rebates, is put forth by the tenderer, shall be summarily rejected.

The Competent Authority, on behalf of TIFR, Hyderabad reserves to itself the right of accepting the whole or any part of the tender and the tenderer shall be bound to perform the same at the rates quoted. The officer inviting tenders shall have the right of rejecting all or any of the tenders and will not be bound to accept the lowest tender or any other tender.



टाटा मूलभूत अनुसंधान संस्थान
TATA INSTITUTE OF FUNDAMENTAL RESEARCH
भारत सरकार के परमाणु ऊर्जा विभाग की स्वायत्त संस्था एवं समविश्वविद्यालय
(An Autonomous Institute of the Department of Atomic Energy,
Government of India, and a Deemed University)

सर्वेक्षण संख्या 36 / पी, गोपनपल्ली गांव, सेरिलिंगमपल्ली मंडल, रंगारेड्डी जिला, हैदराबाद - 500 046
36/P, Gopanpally Village, Serilingampally Mandal, Ranga Reddy District, Hyderabad - 500 046

7. Validity of Tender: The tender for the work shall remain open for acceptance for a period of 75 days from the last date of submission of tenders. If any tenderer withdraws his tender before the said period, or before issue of Letter of Intent, whichever is earlier, or makes any modifications in the terms and conditions of the tender which are not acceptable to the Department, then TIFR, Hyderabad shall, without prejudice to any other right or remedy, be at liberty to forfeit 50% of the said earnest money absolutely. Further the tenderer shall not be allowed to participate in the retendering process of the work.

8. Levy / Taxes payable by contractor:

i. GST or any other tax on materials and services in respect of this contract shall be payable by the contractor and TIFR shall not entertain any claim whatsoever in this respect.

ii. The contractor shall deposit royalty and obtain necessary permits as required for supply of the sand, aggregate, stone etc. from local authorities.

9. Deduction of Income Tax : As per Section 194-C of Income tax Act 1961, as amended by letter No. 275/9/72/9-TJ (Circular No. 86) dated 19.5.72 and No. 275/14/91-IT (B) (Circular No. 593) dated 5.2.91, received from Ministry of Finance, Department of Revenue, Central Board of Direct Taxes, New Delhi, the Income tax @ 2% and Surcharge thereon @12% (or any other amended rate by Ministry of Finance from time to time), of the gross value of the work done will be recovered from the bills. A certificate for the amount recovered will be issued by the Department.

10. Site visit by the tenderer before tendering: Tenderers are advised to inspect and examine the site and its surroundings during working hours and satisfy themselves before submitting their tenders as to the nature of the ground and subsoil (so far as is practicable), the form and nature of the site, the means of access to the site, the accommodation they may require and in general shall themselves obtain all necessary information as to risks, contingencies and other circumstances which may influence or affect their tender. A tenderer shall be deemed to have full knowledge of the site whether he inspects it or not and no extra charges consequent on any misunderstanding or otherwise shall be allowed.

11. Signing of Tender and receipts for payments: In the event of the tender being submitted by a firm, it must be signed separately by each partner thereof or in the event of the absence of any partner, it must be signed on his behalf by a person holding a power-of-attorney authorizing him to do so, such power of attorney to be produced with the tender, and it must disclose that the firm is duly registered under the Indian Partnership Act-1952. Receipts for payments made on account of work, when executed by a firm, must also be signed by all the partners, except where contractors are described in their tender as a firm, in which case the receipts must be signed in the name of the firm by one of the partners, or by some other person having due authority to give effectual receipts for the firm.

12. Tenderer's responsibilities: The tenderer shall be responsible for arranging and maintaining at his own cost all materials, tools & plants, facilities for workers and all other services required for executing the work unless otherwise specifically provided for in the contract documents. Submission of a tender by a tenderer implies that they have read this notice & all other contract documents, and has made himself aware of the scope & specifications of the work to be done and local conditions and factors having a bearing on the execution of the work.



टाटा मूलभूत अनुसंधान संस्थान
TATA INSTITUTE OF FUNDAMENTAL RESEARCH
भारत सरकार के परमाणु ऊर्जा विभाग की स्वायत्त संस्था एवं समविश्वविद्यालय
**(An Autonomous Institute of the Department of Atomic Energy,
Government of India, and a Deemed University)**

सर्वेक्षण संख्या 36 / पी, गोपनपल्ली गांव, सेरिलिंगमपल्ली मंडल, रंगारेड्डी जिला, हैदराबाद - 500 046
36/P, Gopanpally Village, Serilingampally Mandal, Ranga Reddy District, Hyderabad - 500 046

13. Signing of contract: The Notice Inviting Tender shall form a part of the contract document. The successful tenderer / contractor, on acceptance of his tender by the Accepting Authority, shall, within 15 days from the stipulated date of start of the work, sign the contract consisting of: the Notice Inviting Tender, all the documents including all conditions, specifications and drawings, if any, forms the tender as issued at the time of invitation of tender and acceptance thereof together with any correspondence leading thereto.

14. Canvassing: either directly or indirectly, in connection with the tenders is strictly prohibited and the tenders submitted by the contractors who resort to canvassing will be liable to rejection and may be barred from future participation in TIFR works.

Head-Technical Services
For and on behalf of TIFR, Hyderabad



टाटा मूलभूत अनुसंधान संस्थान
TATA INSTITUTE OF FUNDAMENTAL RESEARCH
भारत सरकार के परमाणु ऊर्जा विभाग की स्वायत्त संस्था एवं समविश्वविद्यालय
(An Autonomous Institute of the Department of Atomic Energy,
Government of India, and a Deemed University)

सर्वेक्षण संख्या 36 / पी, गोपनपल्ली गांव, सेरिलिंगमपल्ली मंडल, रंगारेड्डी जिला, हैदराबाद - 500 046
36/P, Gopanpally Village, Serilingampally Mandal, Ranga Reddy District, Hyderabad - 500 046

SECTION-IV

GENERAL CONDITIONS OF CONTRACT

1. Definition of Terms:

- 1.1.**In constructing these general conditions and the specifications the following works shall have the meanings herein assigned to them unless there is something in the subject or context inconsistent with such construction.
- 1.2.**The 'Purchaser' shall mean Tata Institute of Fundamental Research- -Hyderabad, Tata Institute of Fundamental Research, 36/P, Gopanpally Village, Serilingampally Mandal, Ranga Reddy District, Hyderabad 500046 and shall include the Purchaser's heirs, successors and assigns.
- 1.3.**The term 'Engineer In-Charge' and 'Engineer' shall mean Engineer In-Charge, TIFR- Hyderabad or some other person for the time being or from time to time duly appointed in writing by the Purchaser to act as Engineer In-Charge for the purpose of the Contract or in default of such appointment the Purchaser.
- 1.4.**The term 'Contractor'/'Supplier'/'Bidder'/'Vendor' shall mean the Bidder whose tender has been accepted by the Owner and shall include the Bidder's heirs, successors and assigns approved by the Purchaser:
- 1.5.**The term 'Sub-Contractor' shall mean the firm or persons named in the contract for any art of the work or any person to whom any part of the work has been sublet with the consent in writing of the Engineer In-Charge and shall include his heirs, successors and assigns approved by the Purchaser.
- 1.6.**The Term 'Inspector' shall mean any person appointed by or on behalf of the Purchaser to inspect supplies, stores or work under the contract or any person deputed by the Inspector for the purpose.
- 1.7.**The term 'Particulars' shall mean, the following :
- 1.7.1. Specifications
 - 1.7.2. Drawing (ANNEXURE-V)
 - 1.7.3. Sealed Pattern denoting a pattern sealed and signed by the Inspector.
 - 1.7.4. Proprietary make denoting the product of an individual firm.
 - 1.7.5. Any other details governing the construction, manufacture and/or supply as existing for the contract.
- 1.8.**The term 'Specification' shall mean the specifications annexed to or issued with these Conditions of Contract.
- 1.9.**The term 'Site' shall mean the place or places at which the Equipment is to be delivered or work done by the Contractor; and shall include, where applicable, the lands and buildings upon or in which the works are to be executed and shall also include the place or places at which fabrication and other work is being carried out by the Contractor.
- 1.10.**'Electrical Equipment', 'Stores', 'Work' or 'Works' shall mean and include equipment and materials to be provided and work to be done by the Contractor under the Contract.
- 1.11.**The 'Contract' shall mean acceptance of the work order placed on contractor/supplier under section (2) of these conditions and shall include these conditions of Contract, Specifications, Schedule, Drawing, Letter of Intent of the Purchaser and any subsequent amendments mutually agreed upon.
- 1.12.**'Tests on Completion' shall mean such tests which are prescribed by the specifications or have been mutually agreed to between the Contractor/Supplier and the Purchaser to be made before the equipment is taken over by the Purchaser.
- 1.13.**Writing' shall include any manuscript, typewritten or printed statement under or over signature or seal as the case may be. Words importing 'person' shall include firms, companies, corporations and association of individuals whether incorporated or not.



टाटा मूलभूत अनुसंधान संस्थान
TATA INSTITUTE OF FUNDAMENTAL RESEARCH
भारत सरकार के परमाणु ऊर्जा विभाग की स्वायत्त संस्था एवं समविश्वविद्यालय
(An Autonomous Institute of the Department of Atomic Energy,
Government of India, and a Deemed University)

सर्वेक्षण संख्या 36 / पी, गोपनपल्ली गांव, सेरिलिंगमपल्ली मंडल, रंगारेड्डी जिला, हैदराबाद - 500 046
36/P, Gopanpally Village, Serilingampally Mandal, Ranga Reddy District, Hyderabad - 500 046

1.14. Words importing singular shall also include plural and vice versa where context requires.

1.15. Bidders are advised to visit and inspect the work-site to make themselves fully conversant with the site conditions and nature of work. Any claim by them after the opening of bids on account of themselves being unaware of any site condition shall not be entertained.

2. Contract

Contractor/Supplier/Manufacturer should send their acceptance letter on receipt of 'Letter of Intent' or 'Work Order' or 'Purchase Order' within the stipulated period. On expiry of said period or exorbitant delay in commencing or executing the work, the Purchaser shall not be liable to any claim from the Contractor/Supplier for work entrusted to and may revoke the contract.

3. Work at Site

3.1. Access to the works shall be allowed only to the Contractor/Supplier, Sub-Contractors or his duly appointed representatives. The Contractor/Supplier shall not object to the execution of other works by other contractors or tradesmen and shall afford them every facility for execution of their several works simultaneously with his own.

3.2. Work at the Purchaser's premises shall be carried out at such time as the Purchaser may approve but the Purchaser shall give the Contractor/Supplier all reasonable facilities for the same. The Contractor/Supplier shall provide sufficient fencing, notice boards etc. to guard the works and warn the public.

3.3. The Contractor shall obey Central, Local and State regulations and enactments pertaining to workmen and labor and the Engineer In-Charge shall have the right to enquire into and decide all complaints on such matters. The Contractor should comply with the Minimum Wages Act and should also ensure that safe practices are followed by his people at site.

3.4. The contractor should follow safety precautions and maintain safety PPE's to their workmen throughout the project. Penalty will be imposed by TIFRH if violation of safety precautions.

4. Delays

The Contractor/Supplier shall not be entitled to any compensation for any loss suffered by him on account of delays in commencing or executing the work, whatever the cause for such delays may be, including delays in procuring Government controlled or other materials and delay in obtaining instructions and decisions from the Engineer In-Charge.

5. Taking Over

The equipment when erected at site shall be deemed to have been taken over by the Purchaser when the Engineer In-Charge will have certified in writing that the equipment has fulfilled the contract conditions.

6. Extension of Time

If the Contractor/Supplier is delayed in the progress of work by changes ordered in the work, or by any cause, which the Engineer In-Charge shall decide to justify the delay, then the time of completion shall be extended by a reasonable time. In this regard, the Contractor shall maintain a proper hindrance register and record all such events with due signature of E-I-C on occurrence of such instances for seeking extension of



टाटा मूलभूत अनुसंधान संस्थान
TATA INSTITUTE OF FUNDAMENTAL RESEARCH
भारत सरकार के परमाणु ऊर्जा विभाग की स्वायत्त संस्था एवं समविश्वविद्यालय
**(An Autonomous Institute of the Department of Atomic Energy,
Government of India, and a Deemed University)**

सर्वेक्षण संख्या 36 / पी, गोपनपल्ली गांव, सेरिलिंगमपल्ली मंडल, रंगारेड्डी जिला, हैदराबाद - 500 046
36/P, Gopanpally Village, Serilingampally Mandal, Ranga Reddy District, Hyderabad - 500 046

time. However, no such extension shall be allowed unless requested for extension is made in writing by the Contractor/Supplier to the Engineer In-Charge within 15 days from the date of occurrence of the delay.

7. Liquidated Damages

- 7.1.**For all delays, which do not merit any extension of time, the Contractor/ Supplier shall attract 1% penalty per week for the first 4 weeks of delay and 2% penalty per week for the next 4 weeks of the total contract value. The amount of liquidated damages shall be recoverable from the payment due to the Contractor/Supplier up to maximum of 10% of value of contract.
- 7.2.**The deduction of liquidated damages shall not, however, absolve the Contractor/Supplier of his responsibility and obligations under the contract to complete the work in its entirety and shall also be without prejudice to action by the Purchaser under clause:
- 7.3.**'Termination of Contract by the Purchaser'. After that the same shall be completed by the Purchaser at the Contractor's/Supplier's risk and cost.

8. Other Damages:

- 8.1.**The Contractor/Supplier/Manufacturer shall be responsible for all injury to persons, animals or things and for all damage to the works, structure of, and decorative work in the property which may arise from operation or neglect of himself or any of his Subcontractor or of his or Sub-Contractor's employees, whether such injury or damage may arise from carelessness, accident or any other cause whatever in any way connected with the carrying out of this contract. This clause shall be held to include any damage to buildings, whether immediately adjacent or otherwise, any damage to roads, streets, foot paths, as well as all damage caused to the works forming the subject of this contract by frost or other inclemency of weather. The Contractor/Supplier shall indemnify the Purchaser and hold him harmless in respect of all and any expenses on property as aforesaid and also in respect of any claim made in respect of injury or damage under any acts of Government or otherwise and also in respect of any award of compensation or damages consequent upon such claim. Contractor shall furnish necessary insurance documents (Contractor All Risk Policy) taken for the site before commencement of work.
- 8.2.**The Contractor/Supplier/Manufacturer shall reinstate all damage of every sort mentioned in this clause, so as to deliver up the whole of the contract works complete and perfect in every respect and so as to make good or otherwise satisfy all claims for damage to the property of the Owner/third parties.
- 8.3.**The Contractor/Supplier/Manufacturer shall indemnify the Purchaser against all claims which may be made against the Purchaser, by any member of the public or other party, in respect of anything which may arise in respect of the works or in consequence thereof and shall, at his own expense, effect and maintain, until the work has been 'Taken Over' under clause 5.
- 8.4.**The Contractor/Supplier/Manufacturer shall also indemnify the Purchaser against all claims which may be made upon the Purchaser whether under the Workmen's Compensation Act or any other statute in force during the currency of this contract or at common law in respect of any employee of the Contractor/Supplier or of any of his sub-contractor and shall at his own expense effect and maintain until the work has been 'Taken Over', with an approved office. Contractor shall furnish a copy of the labor license before commencement of work. If the aforesaid are not applicable contractor should furnish declaration to this effect and shall indemnify TIFR-Hyderabad, Hyderabad for violation of any such compliances.



टाटा मूलभूत अनुसंधान संस्थान
TATA INSTITUTE OF FUNDAMENTAL RESEARCH
भारत सरकार के परमाणु ऊर्जा विभाग की स्वायत्त संस्था एवं समविश्वविद्यालय
(An Autonomous Institute of the Department of Atomic Energy,
Government of India, and a Deemed University)

सर्वेक्षण संख्या 36 / पी, गोपनपल्ली गांव, सेरिलिंगमपल्ली मंडल, रंगारेड्डी जिला, हैदराबाद - 500 046
36/P, Gopanpally Village, Serilingampally Mandal, Ranga Reddy District, Hyderabad - 500 046

8.5. The Purchaser, with the concurrence of the Engineer In-Charge, shall be at liberty and is hereby empowered to deduct the amount of any damages compensation costs, charges and expenses arising or accruing from or in respect of any such claims or damages from any sums due to or become due to the Contractor/Supplier.

9. Guarantee and Defects Liability Period:

9.1. The Contractor/Supplier/Manufacturer shall guarantee that all equipment shall be free from any defect due to the defective materials and bad workmanship and that the equipment shall operate satisfactorily and that the performance and efficiencies of the equipment shall be not less than the guaranteed values. The guarantee shall be valid for a period of 12 months after the date of commissioning as certified by the Engineer In-Charge. Any parts found defective shall be replaced free of all costs by the Contractor/Supplier. The services of the Contractor's/Supplier's personnel if requisitioned during this period for such work shall be made available free of any cost to the Purchaser.

9.2. If the defects are not remedied within a reasonable time, the Purchaser may proceed to do so at the Contractor's/Supplier's risk and expense without prejudice to any other rights.

10. Terms of Payment

The contractor will be paid only Two Running Account (RA) Bill and Final Bill considering the progress of works based on measurement of works completed. The contractor shall submit the bills for payments along with a detailed statement showing the actual works carried out under different heads of items in the format specified by TIFR-, Hyderabad. Minimum value of the work for interim payment shall be 35% of the work order value.

10.1 Bill Format:

Tender Item No.	Description of Items (At least 2 lines)	Unit	Tender Quantity	Executed Quantity	Rate	%work done	Amount

NOTE: All quantities in the bill should be cumulative.

All measurements should be in the order of tender sequence and should be recorded in the measurement book. The Measurement should be strictly in the below mentioned format only.

10.2. Measurement Format:



टाटा मूलभूत अनुसंधान संस्थान
TATA INSTITUTE OF FUNDAMENTAL RESEARCH
भारत सरकार के परमाणु ऊर्जा विभाग की स्वायत्त संस्था एवं समविश्वविद्यालय
(An Autonomous Institute of the Department of Atomic Energy,
Government of India, and a Deemed University)

सर्वेक्षण संख्या 36 / पी, गोपनपल्ली गांव, सेरिलिंगमपल्ली मंडल, रंगारेड्डी जिला, हैदराबाद - 500 046
36/P, Gopanpally Village, Serilingampally Mandal, Ranga Reddy District, Hyderabad - 500 046

Tender Item No.	Description of Item & Location against each Measurement taken	Nos.	Length	Width	Height	Qty.	Remarks

The works which have been certified for running bills will also be verified along with the final bill and any defects found need to be replaced / rectified by the contractor at his cost. Till the time, the site is handed over in full, it is the contractor's liability to safeguard the works done and completed at site. The Progress of work should not be affected in any way quoting the reason of non-availability of funds / materials / releasing of Running bill. The liability of the contractor is to complete all works in his scope in the scheduled time as per the terms of contract and will not relieve the contractors from his obligations once the Running bill is paid / kept pending.

10.3 Final Payment:

Payments of Final bill shall be made after deduction of security deposit /Performance guarantee as specified. The Security Deposit / Performance guarantee, shall be refunded on expiry of the Defects Liability Period after rectifying all defects to the satisfaction of the TIFR-Hyderabad/E.I.C. The acceptance of payment of the final bill by the Contractor would indicate that he would have no further claim in respect of the work executed.

11. Special conditions of Contract governing supplies of the Equipment of this Tender:

11.1.Scope:

- 11.1.1. This specification covers the supply of material as per the enclosed details and quantities and supervision of erection/installation, testing and commissioning of the material.
- 11.1.2. The Contractor/Manufacturer/Supplier shall quote for all the materials along with accessories as mentioned in the enquiry.
- 11.1.3. All the supply shall be in accordance with relevant I.S. Specifications and recognized standards.

11.2. Inspection & Testing and commissioning of Material:

- 11.2.1. Contractor/Manufacturer/Supplier shall submit the lists of Type Tests and Routine Tests to be conducted on the material in the Technical Data Sheet.
- 11.2.2. All the materials shall be tested at factory as per IS Specifications of material by Purchaser's Engineer In-Charge/Engineers before dispatch at the cost of Contractor/Manufacturer/Supplier.
- 11.2.3. Contractor/Manufacturer/Supplier shall inform the concerned Engineer In-Charge for inspection and testing in accordance and fix up a suitable date for the same.



टाटा मूलभूत अनुसंधान संस्थान
TATA INSTITUTE OF FUNDAMENTAL RESEARCH
भारत सरकार के परमाणु ऊर्जा विभाग की स्वायत्त संस्था एवं समविश्वविद्यालय
(An Autonomous Institute of the Department of Atomic Energy,
Government of India, and a Deemed University)

सर्वेक्षण संख्या 36 / पी, गोपनपल्ली गांव, सेरिलिंगमपल्ली मंडल, रंगारेड्डी जिला, हैदराबाद - 500 046
36/P, Gopanpally Village, Serilingampally Mandal, Ranga Reddy District, Hyderabad - 500 046

11.3. Test Certificates:

Contractor/Manufacturer/Supplier shall submit the Test Certificates of all materials.

11.4. Taxes & Duty:

- 11.4.1. Contractor/Manufacturer/Supplier shall quote the basic price of material. Excise Duty, Custom Duty, Sales Tax, GST, Octroi, Delivery Charges, Transit Insurance and/or any other charges, if any, must be indicated separately.
- 11.4.2. TIFR being a research institute of Govt. of India, is eligible for Excise Duty Exemption on equipment supplies. Necessary exemption certificate will be provided by TIFR.
- 11.4.3. Transit Insurance: The Transit Insurance from the point of dispatch to the site of erection shall be in the scope of Supplier and the cost shall be indicated separately.

11.5. Delivery of Material:

- 11.5.1. The Contractor/Manufacturer/Supplier shall be held responsible for loading of all equipment and for the stores being sufficiently and properly packed for transport by rail, road, sea or air so as to ensure their being free from any loss or damage on arrival at destination. The packing and marking of packages shall be done by and at the expenses of Manufacturer/Supplier. Each package shall contain a packing note quoting purchase order number and detail of the contents.
- 11.5.2. All the materials must be delivered at site i.e. Hyderabad - TIFR at 36/P, Gopanpally Village, Serilingampally Mandal, Ranga Reddy District, Hyderabad-500046. The unloading and positioning of all equipment at the designated locations specified by the Engineer In-Charge shall be in the scope of the Supplier. The Supplier shall arrange for handling equipment, labour for rigging, etc. as required.
- 11.5.3. Material must be delivered at site in all respects as mentioned in the Purchase Order.

11.6. Guarantee:

If during the period of guarantee any fault or defect arises, the material shall be replaced/repared immediately free of cost, as well as any replacement of accessories required shall be done free of cost.

11.7. Mistake in Drawing:

The Contractor/Supplier shall be responsible for and shall pay for any alterations in works due to any discrepancies, errors or omissions the drawings or other particulars supplied by him whether such drawings or particulars have been approved by the Purchaser or not.

11.8. Responsibility for Completeness:

Any fittings or accessories which may not be specifically mentioned in the specifications but which are usual or necessary are to be provided by the Contractor/Supplier without extra charge and the equipment must be complete in all details.



टाटा मूलभूत अनुसंधान संस्थान
TATA INSTITUTE OF FUNDAMENTAL RESEARCH
भारत सरकार के परमाणु ऊर्जा विभाग की स्वायत्त संस्था एवं समविश्वविद्यालय
(An Autonomous Institute of the Department of Atomic Energy,
Government of India, and a Deemed University)

सर्वेक्षण संख्या 36 / पी, गोपनपल्ली गांव, सेरिलिंगमपल्ली मंडल, रंगारेड्डी जिला, हैदराबाद - 500 046
36/P, Gopanpally Village, Serilingampally Mandal, Ranga Reddy District, Hyderabad - 500 046

11.9.Extra/Deviation items & Variations in quantity

TIFR-Hyderabad has the right to omit/delete any of the items and also increase/decrease the quantities mentioned in the tender. No claim or any compensation in this regard will be accepted or paid to the contractor. However, if any new /additional items/deviated items are to be executed, the contractor is bound to execute such items with prior approval from TIFR-Hyderabad after furnishing the proper rate analysis for such extra/deviated items.

11.10.Rejection of Defective Equipment:

- 11.10.1. If the equipment after the acceptance thereof is discovered to be defective, notwithstanding that such defects could have been discovered at the time of inspection or found to have failed to fulfill the requirements of the contract or developed defects after the erection within a period of 12 months from the date of erection, even if such erection is done by the Purchaser, he shall be entitled to give a notice on the Contractor/Supplier setting forth details of such defects or failure and the Contractor/Supplier shall, provided such notice is given within a period of 14 months from the date of such erection or acceptance, forthwith make the defective equipment good or alter the same to make it comply with the requirements of the contract at his own cost and further if in the opinion of the Purchaser, the defects are of such a nature that the defects cannot be made good or required without impairing the efficiency or workability of the equipment or if in the opinion of the Purchaser the Equipment cannot be repaired or altered to make it comply with the requirements of the Contract, the Contractor/Supplier shall, provided a notice given by the Purchaser in this behalf within a period of 14 months from the date of erection or acceptance thereof, remove and replace the same with the equipment conforming to the stipulated particulars, in all respects at the Contractor's/Supplier's own cost. Should he fail to do so within a reasonable time, the Purchaser may reject and replace, at the cost of the Contractor/Supplier, with equipment of the same particulars or if equipment conforming to the stipulated particulars are not in the opinion of the Purchaser readily procurable, such opinion being final, then with the nearest substitutes.
- 11.10.2. In the event of such rejection the Purchaser shall be entitled to use the Equipment in a reasonable and proper manner for a time reasonably sufficient to enable him to obtain replacement equipment as herein before provided.

11.11.Inspection and Final Tests:

All tests necessary to ensure that the Equipment complies with the particulars and guarantee shall be carried out at such place or places as may be determined by the Inspector. Should, however, it be necessary for the final test as to performance or guarantee to be held over until the Equipment is erected at site they shall be carried out within one month of completion of erection.



टाटा मूलभूत अनुसंधान संस्थान
TATA INSTITUTE OF FUNDAMENTAL RESEARCH
भारत सरकार के परमाणु ऊर्जा विभाग की स्वायत्त संस्था एवं समविश्वविद्यालय
(An Autonomous Institute of the Department of Atomic Energy,
Government of India, and a Deemed University)

सर्वेक्षण संख्या 36 / पी, गोपनपल्ली गांव, सेरिलिंगमपल्ली मंडल, रंगारेड्डी जिला, हैदराबाद - 500 046
36/P, Gopanpally Village, Serilingampally Mandal, Ranga Reddy District, Hyderabad - 500 046

11.12.Intimation about Delivery:

If the Purchaser shall have notified the Contractor/Supplier in writing that the former is not ready to take delivery, no equipment or materials shall be forwarded until an intimation in writing shall have been given to the Contractor/Supplier by the Purchaser that he is ready to take delivery.

11.13.Delay in erection:

Wherever erection of an equipment or machinery is the responsibility of the Contractor/Supplier as a term of the contract and in case the Contractor fails to carry out the erection as and when called upon as to do within the period specified by the Purchaser, the Purchaser shall have right to get the erection done through any source of his choice. In such an event, the Contractor/Supplier shall be liable to bear any additional expenditure that the Purchaser may incur towards erection. The Contractor/Supplier shall, however not be entitled to any gain due to such an action by the Purchaser.

11.14.Definition of Equipment:

The work 'Equipment' wherever, it appears in these 'Special Conditions of Contract' governing supplier of Equipment in this Tender shall mean all switchgears, panels, etc. or parts thereof or what the Contractor/Supplier agrees to supply under Contract as specified in the work order.

11.15.Force Majeure:

Normally Force Majeure shall cover only acts of God, fire, wars, strike, riots and civil commotion, floods, epidemic, quarantine related strikes, freight embargoes, etc. The contractor shall not be liable for any liquidated damages for delay or any failure to perform the contract arising out of Force Majeure conditions, provided that the contractor shall within ten days from the beginning of such delay notify the department in writing the cause of delay along with convincing supporting evidence. The department once convinced and accepted the reason may extend the supply completion period by a suitable / reasonable margin.

11.16.Termination of Contract by the Purchaser:

- 11.16.1. If the Contractor/Supplier commits any 'Act of Insolvency' or shall be adjudged an Insolvent or shall have an order for compulsory winding up made against him or pass effective resolution for winding up voluntarily, or if the Contractor/Supplier shall suffer any payment under this contract to be attached by or on behalf of any of the creditors of the Contractor/ Supplier, or shall assign the Contract without the prior consent in writing of the Engineer In-Charge, or shall charge or encumber this Contract or any payments due or which may become due to the Contractor/Supplier there under, or if the Engineer In-Charge shall certify in writing to the Purchaser that the Contractor/Supplier –

- 11.16.1.1. has abandoned the Contract, or



टाटा मूलभूत अनुसंधान संस्थान
TATA INSTITUTE OF FUNDAMENTAL RESEARCH
भारत सरकार के परमाणु ऊर्जा विभाग की स्वायत्त संस्था एवं समविश्वविद्यालय
**(An Autonomous Institute of the Department of Atomic Energy,
Government of India, and a Deemed University)**

सर्वेक्षण संख्या 36 / पी, गोपनपल्ली गांव, सेरिलिंगमपल्ली मंडल, रंगारेड्डी जिला, हैदराबाद - 500 046
36/P, Gopanpally Village, Serilingampally Mandal, Ranga Reddy District, Hyderabad - 500 046

-
- 11.16.1.2. has failed to commence the works, or has without any lawful excuse these conditions suspended the progress of the works for seven days after receiving from the Engineer In-Charge written notice to proceed, or
- 11.16.1.3. has failed to proceed with the work with such due diligence and failed to make such due progress as would enable the works to be completed in accordance with the approved programme of work,, or
- 11.16.1.4. has failed to remove materials from the site or to pull down and replace work for seven days after receiving from the Engineer In-Charge written notice that the said materials or work were condemned and rejected by the Engineer In-Charge under these conditions, or
- 11.16.1.5. has neglected or failed persistently to observe and perform all or any of the acts matters or things by this contract to be observed and performed by the Contractor for seven days after written notice shall have been given to the Contractor/ Supplier requiring the Contractor/Supplier to observe or perform the same, or
- 11.16.1.6. has to the detriment of good workmanship or in defiance of the Engineer In-Charge's instructions to the contrary sub-let any part of the contract, then and in any of the above said causes, the Purchaser with the written consent of the Engineer In-Charge may, notwithstanding any previous waiver, after giving seven days' notice in writing under the provisions of this clause to the Contractor/Supplier, determine the contract but without prejudice to the powers of the Engineer In-Charge or the obligations and liabilities of the Contract, the whole of which shall continue to be in force as if the contract has not been so determined and as if the work subsequently executed has been executed by and on behalf of the Contractor/ Supplier.
- 11.16.2. After the issue of such notice, the Contractor/Supplier shall not be at liberty to remove from site any equipment, tools and materials belonging to him which shall have been placed thereon for the purpose of the works and the Purchaser shall have lien upon such equipment, tools or materials to subsist from the date of such notice and until the notice shall have been complied with.
- 11.16.3. If the Contractor/Supplier shall fail to comply with the requirements of said notice for seven days after such notice has been given, the Purchaser shall have the power to enter upon and take possession of the works and site and all equipment, tools and materials thereon, and to engage any other person, firm or agency to complete the works, utilizing the equipment, tools and materials to the extent possible. The Purchaser shall not in any way be responsible for damage or loss of the tools, equipment and materials and the Contractor/Supplier shall not have any compensation therefore.
- 11.16.4. Upon completion of the works, the Engineer In-Charge shall certify the amount of expenditure properly incurred consequent on and incidental to the default of the Contractor/Supplier as aforesaid and such amount shall be deducted from the payments due to the Contractor/Supplier, including the Security Deposit. If the said amount exceeds the payment due to the Contractor/Supplier, the Purchaser shall be at liberty to dispose



टाटा मूलभूत अनुसंधान संस्थान
TATA INSTITUTE OF FUNDAMENTAL RESEARCH
भारत सरकार के परमाणु ऊर्जा विभाग की स्वायत्त संस्था एवं समविश्वविद्यालय
**(An Autonomous Institute of the Department of Atomic Energy,
Government of India, and a Deemed University)**

सर्वेक्षण संख्या 36 / पी, गोपनपल्ली गांव, सेरिलिंगमपल्ली मंडल, रंगारेड्डी जिला, हैदराबाद - 500 046
36/P, Gopanpally Village, Serilingampally Mandal, Ranga Reddy District, Hyderabad - 500 046

off any of the Contractor's/Supplier's materials, tools or equipment and apply the proceeds for the payments due from the Contractor/Supplier and recover the balance by process of law.

- 11.16.5. After the works have been completed after the amounts due to the Contractor/Supplier, the Engineer In- Charge shall give notice in writing to the Contractor/Supplier to remove the surplus equipment and material from site. If such equipment and materials are not removed within a period of 14 days after such notice, the Purchaser shall have the power to remove and sell the same holding the proceeds less the cost of removal and sale, to the credit of the Contractor/Supplier. The Purchaser shall not be responsible for any loss sustained by the Contractor/Supplier from the sale of the equipment and material.

12. Contractor's Representative:

The Contractor/Supplier shall employ at least one qualified representative (i.e.Hvac supervisory License with minimum 3 years of experience of similar works as stipulated by TIFR- Hyderabad in the work order) whose name shall have previously been communicated in writing to the Engineer In-Charge and approved by him to supervise the erection. Any written order or instructions given to the representative shall be deemed to have been given to the Contractor/Supplier. The Engineer In-Charge shall be at liberty to object to any particular representative/or any persons employed by the Contractor/Supplier on the work and the Contractor/Supplier shall remove the person objected to, on the receipt of the Engineer In-Charge, in writing, a request requiring him to do so and shall provide in his place another competent representative acceptable to the Engineer In-Charge.

The Contractor's/Supplier's representative shall be a qualified electrical/ mechanical engineer possessing adequate site experience in similar nature of works.

13. Completion Time:

Unless otherwise agreed in writing between the Purchaser and the Contractor/Supplier, the work contract shall be completed within the stipulated period mentioned elsewhere in this tender document from the date of Work/Purchase Order issued to Contractor/Supplier by the Purchaser.

14. Delivery of Material at Site:

The Contractor/Supplier/Manufacturer shall arrange for safe transit and delivery of material at site and unloading the material at site.

15. Validity of Tender:

The quotation should be valid for 75 days after opening of the Part—I: Technical Bids.



टाटा मूलभूत अनुसंधान संस्थान
TATA INSTITUTE OF FUNDAMENTAL RESEARCH
भारत सरकार के परमाणु ऊर्जा विभाग की स्वायत्त संस्था एवं समविश्वविद्यालय
(An Autonomous Institute of the Department of Atomic Energy,
Government of India, and a Deemed University)

सर्वेक्षण संख्या 36 / पी, गोपनपल्ली गांव, सेरिलिंगमपल्ली मंडल, रंगारेड्डी जिला, हैदराबाद - 500 046
36/P, Gopanpally Village, Serilingampally Mandal, Ranga Reddy District, Hyderabad - 500 046

16. Measurements:

All joint measurements of quantities shall be done by the Contractor at his own cost in the presence of the Engineer In-Charge or any authorized person deputed by him who will certify the routes, length and quantities etc. for the purpose of determination of the amount payable.

17. Spare Parts & Manuals:

Manufacturer/Contractor/Supplier should submit operation, maintenance and spare part list and manuals for all equipment.

18. Training:

Manufacturer/Contractor/Supplier should provide training for operation and maintenance free of cost for equipment supplied.

19. Special Instruction for bidding process

This tender is a two part tender. The Part-I: Technical Bid and Part-II: Financial Bid. Bidders shall seal each bid separately with a clear label on the envelope about its content. Both the bids should be submitted in a single drop two cover method. Any pricing details must not appear in the Part-I: Technical Bid.

20. Drawings and Documentation:

Contractor should make and submit the drawing as per the site conditions and take approval from EIC. As-built drawings as specified in this technical specifications shall be submitted by the Contractor.

21. Permissions and Approvals:

All statutory permissions and approvals from Electricity authority as may be required for commissioning of the entire system shall be carried out by the contractor. All necessary documentation for obtaining such permissions and approvals shall be done by the contractor. Purchaser shall assist in providing required declarations. Statutory fees shall be paid by the purchaser.

22. Guarantee:

The equipment shall be guaranteed against all design and manufacturing defects, poor workmanship etc. for a period of 12 months from the date of commissioning or 15 months from the date of supply, whichever is earlier. Any defects discovered during this period shall be rectified by the vendor free of cost to the purchaser.



टाटा मूलभूत अनुसंधान संस्थान
TATA INSTITUTE OF FUNDAMENTAL RESEARCH
भारत सरकार के परमाणु ऊर्जा विभाग की स्वायत्त संस्था एवं समविश्वविद्यालय
(An Autonomous Institute of the Department of Atomic Energy,
Government of India, and a Deemed University)

सर्वेक्षण संख्या 36 / पी, गोपनपल्ली गांव, सेरिलिंगमपल्ली मंडल, रंगारेड्डी जिला, हैदराबाद - 500 046
36/P, Gopanpally Village, Serilingampally Mandal, Ranga Reddy District, Hyderabad - 500 046

SECTION-V

TECHNICAL SPECIFICATION

TECHNICAL SPECIFICATION

1. VERTICAL INLINE PUMPS:

- Pumps shall be vertical in line pumps suitable for vertical / horizontal mounting without base foundation.
- Pumps shall be supported on the pipe lines. Pump volute shall be Class 30 CI. Impeller shall be cast bronze enclosed type, dynamically balanced. Internally flushed mechanical seal with ceramic seal seat and carbon seal ring suitable for continuous operation shall be provided. Replaceable bronze shaft sleeves shall completely cover the wetted area under the seal.
- Pumps shall be rated min. 300 psi pressure. Volute shall have gauge tapings, vent and drain tapings.
- Motor shall meet NEMA specifications. Motor and pump shall be factory aligned. It shall be suitable to work in an open area with 110 deg. F ambient temperature. Base plate shall be of structural steel or fabricated steel channel with fully enclosed sides and ends and securely welded cross members. A flexible type, center design drop out coupler, capable of absorbing tensional vibration shall be used between the pump & motor. Coupler shall be shielded by a coupler guard. Pump set shall be factory painted with weather protected paint. Pumps shall be rated at 300 psi pressure. Volute shall have gauge tapings, vent and drain tapings.
- These should be Direct coupled design eliminates stub shaft, oiled bearing and coupling, reducing maintenance.

2. FLOOR MOUNTED HORIZONTAL AIR HANDLING UNITS (AHUs):

2.1 Coil Section:

- Removing of existing stand by DX cooling coil and supply, installation, testing & commissioning of new 8 row chilled water coils. This is to be carried out without damaging the existing working DX cooling coil. 100% Fresh air coil to be selected for Hyderabad conditions. Coil selection shall be submitted for review and approval. Existing AHUs and coils are of Zeco make.
- The proposed Chilled water coils shall be constructed from 12 / 16 mm OD copper tubes 24 gauge wall thickness, mechanically bonded to aluminum fins of 34 / 36 gauge thickness and assembled within a heavy gauge galvanized steel frame work. Coils shall be provided with air vent and drain plugs. Coil assembly shall be supported on slide frames for easy withdrawal.
- Chilled water coil shall be complete with a double skin drain pan constructed from stainless steel sheet and shall be installed inside the double skin panel to avoid condensation. The
- Drain pan shall be fitted with drainage coupling on both sides. Drain tray shall have the three directional slopes.



टाटा मूलभूत अनुसंधान संस्थान
TATA INSTITUTE OF FUNDAMENTAL RESEARCH
भारत सरकार के परमाणु ऊर्जा विभाग की स्वायत्त संस्था एवं समविश्वविद्यालय
(An Autonomous Institute of the Department of Atomic Energy,
Government of India, and a Deemed University)

सर्वेक्षण संख्या 36 / पी, गोपनपल्ली गांव, सेरिलिंगमपल्ली मंडल, रंगारेड्डी जिला, हैदराबाद - 500 046
36/P, Gopanpally Village, Serilingampally Mandal, Ranga Reddy District, Hyderabad - 500 046

3. PIPING WORKS:

- The scope of this section comprises the supply and laying of all piping works, chilled water piping, drain piping, allied works like fixing of valves and other accessories involved in this project.

3.1. MATERIAL:

- All chilled water shall be of MS **Class C** ERW pipe and shall conform to IS 1239 Standards & joints shall be welded.
- All piping 450 mm dia. and over, shall be fabricated using MS plates of thickness indicated below:

Pipe dia – mm

- Upto 150 mm dia.
- 200 mm dia.
- 250 & 350 mm dia.
- 400 & above

Thickness – mm

- : MS Class 'C' as per IS 1239 Part - I
- : 6 mm as per IS 3589
- : 6 mm as per IS 3589
- : 7 mm as per IS 3589

Pipe Fittings dia(mm)

- Up to 150 mm dia.
- Above 150 mm dia.

Specification

- : MS to IS 1239 Part - II
- : To be fabricated from parent pipe

Pipe Flanges as per IS 6392 Table 17.

3.2. FABRICATION AND INSTALLATION:

- The ends of pipe lengths to be welded shall be cut square by saw or cutter and the edges beveled to form a 'V' groove before welding.
- The contractor shall design adequately all brackets, saddles, clamps, hangers, etc., and be responsible for structural safety and integrity. Further, while providing the supports, care shall be taken to ensure freedom from vibration.
- All supporting arrangements including necessary suspenders, brackets, rods, bolts and nuts, etc., and all civil work related thereto - including drilling of holes for fixing grip bolts and any chipping and finishing, shall be included within the scope of the work of the contractor and shall be carried out under the scope of HVAC system.
- All MS angles, channels, rods, brackets, etc., used for supporting arrangements shall be provided with a coat of red-oxide primer both before and after placing them in position. All supports shall be finally painted with two coats of black enamel paint.



टाटा मूलभूत अनुसंधान संस्थान
TATA INSTITUTE OF FUNDAMENTAL RESEARCH
भारत सरकार के परमाणु ऊर्जा विभाग की स्वायत्त संस्था एवं समविश्वविद्यालय
(An Autonomous Institute of the Department of Atomic Energy,
Government of India, and a Deemed University)

सर्वेक्षण संख्या 36 / पी, गोपनपल्ली गांव, सेरिलिंगमपल्ली मंडल, रंगारेड्डी जिला, हैदराबाद - 500 046
36/P, Gopanpally Village, Serilingampally Mandal, Ranga Reddy District, Hyderabad - 500 046

- Vertical risers shall be parallel to walls and column lines and shall be straight and plumb. Risers passing from floor to floor shall be supported at each floor by clamps or collars attached to pipes and transmitting the load to the structure through 12 mm (1/2 ins.) Thick rubber pad or any suitable resilient material. Where pipes pass through the terrace floor, suitable flashing shall be provided to prevent leakage. Risers shall also have a suitable elbow or concrete pipe support at the lowest point.
- Pipe sleeves of 50 mm & larger in diameter shall be provided wherever pipes pass through walls or structures and the annular space shall be filled with felt and finished with retaining rings to isolate any vibrations from being transmitted to walls/structures. Fire sealant shall be used wherever is required.
- Insulated piping shall be supported in such a manner as not to put undue pressure on the insulation. 14 G GSS shall be provided between the insulation and the clamp, the saddle or roller extending at least 100 mm on either side (of the clamp, saddle or roller). The method of support shall be approved by the Consultants / Project Managers. PUF saddles of 120 kg/cub. Mt. shall be used for supporting the piping on the channels / concrete pedestals. PUF saddles shall be painted with bituminous paint.

3.3.SUPPORT SPACINGS:

The following spacing is recommended for the pipe supports:

Pipe dia – mm	Spacing of Supports - Mtr
➤ 19 to 25 mm	1.80
➤ 32 to 150 mm	2.40
➤ 150 mm & above	2.40

4.CHILLED WATER PIPES INSULATION FOR ABOVE GROUND LEVEL:

- Chilled water shall be done with MS Class 'C' ERW piping with welded construction as per the piping specifications. The surface to be insulated shall be first cleaned and a coat of zinc chromate primer shall be given. The insulation shall be fixed tightly to the surface with hot bitumen/cold setting adhesive CPRX compound as recommended by the insulation manufacturer. All joints shall be staggered and sealed. The second layer of insulation shall be similarly applied over the first layer.

4.1.THE INSULATION SHALL BE FINISHED AS UNDER:

- For pipes laid inside the building, the insulation over the pipe work shall be finished with 0.63 mm thick aluminum sheet cladding over the a vapour barrier of 120 gm/sq. m. polythene sheet with 50 mm overlap and tied down with lacing wire and complete with type 3, grad-1 roofing felt strip (as per IS 1322 as amended up to date) at the joints. The expanded polystyrene insulation of density not less than 20Kg per cu.m. Shall be used.



टाटा मूलभूत अनुसंधान संस्थान
TATA INSTITUTE OF FUNDAMENTAL RESEARCH
भारत सरकार के परमाणु ऊर्जा विभाग की स्वायत्त संस्था एवं समविश्वविद्यालय
(An Autonomous Institute of the Department of Atomic Energy,
Government of India, and a Deemed University)

सर्वेक्षण संख्या 36 / पी, गोपनपल्ली गांव, सेरिलिंगमपल्ली मंडल, रंगारेड्डी जिला, हैदराबाद - 500 046
36/P, Gopanpally Village, Serilingampally Mandal, Ranga Reddy District, Hyderabad - 500 046

-
- All the valves, fittings, strainers etc... shall be insulated to the same thickness and in the same manner as for the respective piping, taking care to allow operation of valves without damaging the insulation.

5. VALVES:

5.1. BUTTERFLY VALVES:

- Butterfly valves shall be of slim seal, short wafer type with standard finish. The valves shall be suitable for mounting between flanges drilled to ANSI 125. The valve body shall be cast iron. The disc shall consist of cast Bronze or Stainless Steel. The disc shall move in bearings on both ends with 'O' Ring to prevent leakage. The seat shall be either integral or Nitrile rubber. The valves shall be of PN 16 rating shall be complete with flow control lever and notches, factory machined companion flanges, bolts & nuts.

5.2. Y-STRAINERS:

- "Y" strainers up to 50 mm shall be of gunmetal and above 50 mm shall be of cast iron body. Strainers shall have a removable bronze/ stainless steel minimum 1mm thick screen with 3 mm perforations and a permanent magnet. Strainers shall be provided with flanges or threaded sockets as required. They shall be designed to enable blowing out the accumulated dirt and facilitate removal / replacement of screen without disconnecting the main pipe. Strainers shall be provided with a flushing valve, nipple and dummy. "Y" strainers shall be of PN 16 rating. The valves shall be installed with threaded nipples with unions / flanges as required for easy removal. These valves shall have insulation with the same specifications of pipe insulation.

5.3. NON-RETURN VALVES:

- Non-Return valves shall be of gun metal construction upto 65 mm, the metal conforming to class 2 of IS: 778. For 75 mm and above, the valve shall be of bronze or gunmetal, body being of cast iron. While screwed or flanged ends may be provided up to 65 mm, flanged ends shall be provided for larger sizes. The Non-Return valves shall be of PN 16 rating. The valves shall be installed with threaded nipples with unions / flanges as required for easy removal. These valves shall have insulation with the same specifications of pipe insulation

5.4. GATE VALVES / GLOBE VALVES / BALL VALVES:

- Gate valves of smaller diameter shall be made of gun metal with screw ends. In case of ball valves, the rotating ball shall be made of SS. All such valves shall be supplied with I.S.I marking. Valves shall have Teflon seating. The valves shall be installed with threaded nipples with unions / flanges as required for



टाटा मूलभूत अनुसंधान संस्थान
TATA INSTITUTE OF FUNDAMENTAL RESEARCH
भारत सरकार के परमाणु ऊर्जा विभाग की स्वायत्त संस्था एवं समविश्वविद्यालय
(An Autonomous Institute of the Department of Atomic Energy,
Government of India, and a Deemed University)

सर्वेक्षण संख्या 36 / पी, गोपनपल्ली गांव, सेरिलिंगमपल्ली मंडल, रंगारेड्डी जिला, हैदराबाद - 500 046
36/P, Gopanpally Village, Serilingampally Mandal, Ranga Reddy District, Hyderabad - 500 046

easy removal. These valves shall have insulation with the same specifications of pipe insulation. The pressure rating of the valves shall be PN 16.

5.5. FLANGES & UNIONS:

- Sufficient number of flanges and unions shall be provided as required to facilitate the maintenance work after the piping is installed. Necessary gaskets shall be used. These shall be insulated with the same specifications of pipe insulation.

5.6. PRESSURE GAUGES:

- Pressure gauges shall not be less than 100 mm dia. Industrial type pressure gauges with gun metal/ brass valves. Chilled water pipe insulation shall not be damaged during removal and refixing of pressure gauge.

5.7. THERMOMETERS:

- These shall not be less than 100 mm dia. The mercury in glass industrial type thermometer. Chilled water pipe insulation shall not be damaged during removal and refixing of the thermometer.

5.8. BALANCING VALVES:

- Manual Balancing Valve with built in measuring facility with CI body flanged construction with EPDM coated disc with long pitch, with insulation, with matching flanges, gasket, bolt & nuts, insulation, etc. Duly insulated to the same specifications as the connected piping. Pressure rating shall be PN 16.

6. CHILLER SPECIFICATION:

- Chiller with Multi / single scroll Compressor/Screw with Hermetically sealed type with motor, suitable for 400±10% volts, 50 cycles AC supply. Independent Refrigerant Circuit with R-410A/ R-134A refrigerant with compressor, Shell and Tube/ PHE Evaporator including Safety Switch, Pressure Transducer, High Pressure Switch, Compressor Suction and Discharge Shut Off Valves, Condenser Coil, Condenser fan motor, Electronic/ Thermostatic Expansion Valve as per OEM. The following capacities shall be delivered capacities under ambient temperature of 45 deg. C and chilled water in and out temperatures of 10.5 / 5 deg. C. Chilled water out temperature of 5 deg. C is very important to maintain the required RH inside. Chillers shall be capable of operating under ambient temperatures of 50 deg. C. Chiller selection sheet shall be submitted along with the offer. Shall be capable of integrating with a third party BMS system. Necessary modbus RS 485 or Bacnet integrator shall be supplied and installed. All the parameters shall be shown and shall be coordinated with BMS vendor for integration with existing BMS system. Chillers shall be installed with necessary vibration isolators. 60 TR actual delivered capacity



टाटा मूलभूत अनुसंधान संस्थान
TATA INSTITUTE OF FUNDAMENTAL RESEARCH
भारत सरकार के परमाणु ऊर्जा विभाग की स्वायत्त संस्था एवं समविश्वविद्यालय
(An Autonomous Institute of the Department of Atomic Energy,
Government of India, and a Deemed University)

सर्वेक्षण संख्या 36 / पी, गोपनपल्ली गांव, सेरिलिंगमपल्ली मंडल, रंगारेड्डी जिला, हैदराबाद - 500 046
36/P, Gopanpally Village, Serilingampally Mandal, Ranga Reddy District, Hyderabad - 500 046

under above conditions. Necessary Computer selection with Model / catalogs to be submitted with quote for evaluation. The chiller package shall be BMS compatible. The control panel shall incorporate BMS integrator for complete integration of data of microprocessor panel with BMS as per the specifications. The chiller control panel should have provision to accept armoured cable or necessary cable boxes with flexible cables needs to be provided. Should include flow switches, victaulic couplings etc . Desired capacity to be at AHRI condition with minimum COP as per ECBC standard. Chiller should be AHRI Certified.

7. 3 WAY MOTORIZED CONTROL VALVE:

- 3-way motorized Control Valve for chilled water application , having efficient flow characteristics with copper alloy metal gun body and disc must be copper alloy rod and bars EPDM diaphragm screw and unique connections. This includes smart actuator with provision of fail safe opening provision (manual operation button with lock) , Actuator should be provided with appropriate enclosure to protect from rain,with required supports and accessoires like flanges, bolts, nuts | gaskets, pressure rating PN 25. It should have a provision of an auto closing module able to set the valve to Zero signal position when the AHU motor is stopped which includes integrating cables between AHU starter , Actuator and thermostat . Consider that the starters are having one no spare NC point. The control cable qty within 12 rmt per AHU to be included . Actuator Voltage either 24V AC/DC, control signal either 0-10 V DC or 4-20 ma. Vendor to submit the selection for approval. Necessary temperature controllers shall be provided for maintaining the required return air / exhaust air temperature.

8.FLEXIBLE CONNECTORS::

- The flexible connectors shall be with AISI 321 SS corrugated tubing with AISI 304 SS single overbraid & SS fittings.



टाटा मूलभूत अनुसंधान संस्थान
TATA INSTITUTE OF FUNDAMENTAL RESEARCH
भारत सरकार के परमाणु ऊर्जा विभाग की स्वायत्त संस्था एवं समविश्वविद्यालय
(An Autonomous Institute of the Department of Atomic Energy,
Government of India, and a Deemed University)

सर्वेक्षण संख्या 36 / पी, गोपनपल्ली गांव, सेरिलिंगमपल्ली मंडल, रंगारेड्डी जिला, हैदराबाद - 500 046
36/P, Gopanpally Village, Serilingampally Mandal, Ranga Reddy District, Hyderabad - 500 046

APPROVED MAKES

S.No.	ITEM	APPROVED MAKES
1	CHILLER	Bluestar/Daikin/Trane/Equivalent.
2	M.S.PIPING	Jindal / Tata/SAIL/Equivalent
3	EPS INSULATION	Beardshell/Modifoam/Equivalent
4	FLEXIBLE BELLOW	ResistoFlex/Cori/Kanwal//Equivalent
5	BUTTERFLY VALVE	Advance / Audco/Honeywell/Equivalent
6	MANUAL BALANCING VALVE	Advance/Castle/Equivalent
7	3 WAY MOTORIZED VALVE	Danfoss/Belimo//Equivalent
8	Y-STRAINERS	Trishul/Sant/Equivalent
9	GLOBE VALVE/BALL VALVE	Leader/Zoloto/Equivalent
10	TEMPERATURE,PRESSURE GAUGES	HGURU/Emerald/Waree/Equivalent
11	NRV	Advance/Castle/Honeywell/Equivalent
12	PUMPS	Grundfos/Armstrong/Xylem/Equivalent
13	AIR VENT	Leader/Anergy/Equivalent
14	Others Items	As approved by TIFR



टाटा मूलभूत अनुसंधान संस्थान
TATA INSTITUTE OF FUNDAMENTAL RESEARCH
भारत सरकार के परमाणु ऊर्जा विभाग की स्वायत्त संस्था एवं समविश्वविद्यालय
**(An Autonomous Institute of the Department of Atomic Energy,
Government of India, and a Deemed University)**

सर्वेक्षण संख्या 36 / पी, गोपनपल्ली गांव, सेरिलिंगमपल्ली मंडल, रंगारेड्डी जिला, हैदराबाद - 500 046
36/P, Gopanpally Village, Serilingampally Mandal, Ranga Reddy District, Hyderabad - 500 046

STANDARDS

1. IS: 659 - Safety Code for A/C System
2. IS: 1239 Part I – MS Tubes & Pipes
3. IS: 1239 Part II – Pipe Fittings
4. IS: 3589 – MS pipes
5. IS: 6392 – Pipe Flanges
6. IS: 5312 – Check Valves
7. IS: 8183 – Thermal Insulation
8. IS: 325 - 3 phase induction motor
9. IS: 2379 - Color code for identification of pipelines
10. IS: 3103 - Code of Practice for industrial Ventilation
11. ASHRAE Standards for Health Care
12. Carrier System Design Manual
13. JCI Standard for Hospitals.
14. ISO 14644 Cleanroom classification standards.



टाटा मूलभूत अनुसंधान संस्थान
TATA INSTITUTE OF FUNDAMENTAL RESEARCH
भारत सरकार के परमाणु ऊर्जा विभाग की स्वायत्त संस्था एवं समविश्वविद्यालय
(An Autonomous Institute of the Department of Atomic Energy,
Government of India, and a Deemed University)
सर्वेक्षण संख्या 36 / पी, गोपनपल्ली गांव, सेरिलिंगमपल्ली मंडल, रंगारेड्डी जिला, हैदराबाद - 500 046
36/P, Gopanpally Village, Serilingampally Mandal, Ranga Reddy District, Hyderabad - 500 046

MEASUREMENTS METHODOLOGY

Mode of Measurement for payment of items of piping & their insulation shall be as follows:

1.PIPING:

- Shall be measured in units of length along the centerline of installed pipes including all pipe fittings, flanges (with gaskets and nuts and bolts for joining), unions, bends, elbows, tees, concentric and/or eccentric reducers, inspection pieces, expansion loops etc. The above accessories shall be measured as part of piping length along the centerline of installed pipes and no special rates for these accessories shall be permitted. The quoted unit rates for center line linear measurement of piping shall include all wastage, allowances, pipe supports includes hangers, MS channel, wooden bunches, nuts and check nuts, vibration isolator suspension where specified or required, and cost of excavation, bedding back filling and finishing as required to complete the piping installation as per the specification. None of these items will be separately measured and paid for. However, all valves (gate/ globe/butterfly/check -balancing/purge/drain etc.), strainers, orifice plates, temperature gauge, pressure gauges shall be separately measured and paid as per their individual unit rates, which shall also include their insulation as per specifications, piping measurements shall be taken before application of the insulation. The cost shall also include any excavations and making masonry valve chamber with steel cover etc.

2.PIPE INSULATION:

- Shall be measured in units of length along the centerline of the installed pipe, strictly on the same basis as the piping measurements described above. It may be noted that for piping measurements, all valves, orifice plates and strainers are separately measurable and their quoted unit rates shall include the insulation cost in the valve required and as specified.



TESTING PROCEDURE AT SITE

1.GENERAL:

- The Contractor must perform all inspections and tests of the system as a whole and of components individually as required, under the supervision of the Engineer, in accordance with the provisions of the applicable 'ASHRAE' standards or approved equal and as per site requirements. All tests shall be recorded in the format approved by the Consultant/Owner.

2.PIPING SYSTEM PRESSURE TESTING & CHEMICAL FLUSHING:

- In general pressure tests shall be applied to piping only before connection of equipment and appliances. In no case shall piping, equipment appliances be subjected to pressures exceeding their test ratings. Tests shall be completed and approved before insulation is applied. After tests have been completed, the system shall be drained and cleared of all dust and foreign material. All strainers, valves and fittings shall be cleaned of all dirt, fillings and debris. All water piping shall be tested and proven tight under hydrostatic pressure of 10 Kg/Sq cm, unless stated otherwise in the specifications. The prescribed pressure shall be maintained at least three complete days of 24 hours each.
 - Fill the system with clean water and drain the water after 30 minutes.
 - Refill the system with clean water and run the chilled water pump for 2 hours.
 - Open the drain valves in the main lines and drain the water completely. Clean the strainers.
 - During the flushing process the drain valves shall be kept open while the pump is running, until the water appears clean.
 - Close all the drain valves.
 - Refill the system with clean water and add chemicals in required quantities as per Specialist supplier's instructions).
 - Samples of solution shall be collected from various parts of the system to ensure the chemical solution has reached all parts of the system.
 - Run the pump and circulate the water (with chemicals added) for a minimum period of 24 hours as per specialist supplier's recommendations
 - .After the cleaning process is completed as described above the cleaning solution shall be flushed out.
 - The entire system is re-filled with fresh and clean water and treated with corrosion and scale inhibiting treatment chemicals as approved.



टाटा मूलभूत अनुसंधान संस्थान
TATA INSTITUTE OF FUNDAMENTAL RESEARCH
भारत सरकार के परमाणु ऊर्जा विभाग की स्वायत्त संस्था एवं समविश्वविद्यालय
(An Autonomous Institute of the Department of Atomic Energy,
Government of India, and a Deemed University)

सर्वेक्षण संख्या 36 / पी, गोपनपल्ली गांव, सेरिलिंगमपल्ली मंडल, रंगारेड्डी जिला, हैदराबाद - 500 046
36/P, Gopanpally Village, Serilingampally Mandal, Ranga Reddy District, Hyderabad - 500 046

3.ELECTRICAL EQUIPMENT:

All electrical equipment shall be cleaned and adjusted at site before connection of power. The contractor as per relevant IS/IE rules shall carry out the following minimum tests:

- Wire and Cable continuity tests.
- Insulation resistance test between phase to phase, phase to earth and phase to neutral on all circuits and equipment, using a 1000 volt Megger.
- The earth resistance between the conduit system and earth must not exceed half (0.5) ohm.
- The phase rotation tests.
- Operating tests on all protective relays to prove their correct operation before energizing the main equipment including secondary injection test at site.
- Operating tests on all starters, circuit breakers etc.,

4.PERFORMANCE TESTS:

- The installation as a whole shall be balanced and tested upon completion and all relevant information shall be submitted to the owner. Electrical current reading in Amperes of full and average load running and starting together with name plate current in each electrical motor. Daily records should be maintained of hourly readings, taken under varying degrees of internal heat load and use and occupation, of wet and dry bulb temperatures, upstream 'ON-COIL' of each cooling coil. Also suction temperatures and pressures for each refrigerating unit. The current and voltage drawn by each machine. Any other reading shall be taken which the Engineer may subsequently specify.

5.ACCEPTANCE TEST AND SEASONAL TESTS:

- After completing all installation works, commissioning, water balancing and air balancing, acceptance tests shall be conducted for 24 hours recording temperature, humidity, equipment inlet & outlet conditions, power consumption readings, etc. Necessary schedules with test formats shall be submitted for approval before starting the test.
- Seasonal test shall be done for 24 hours during warranty period when peak summer and peak monsoon occurs recording all the above readings.
- The above tests shall be repeated if major abnormality is observed during the tests in achieving the conditions or functioning of equipment.
- Sufficient manpower with tools and tackles shall be arranged for successful completion of the above tests. Necessary data loggers shall be used during the tests for recording various readings.



टाटा मूलभूत अनुसंधान संस्थान
TATA INSTITUTE OF FUNDAMENTAL RESEARCH
भारत सरकार के परमाणु ऊर्जा विभाग की स्वायत्त संस्था एवं समविश्वविद्यालय
(An Autonomous Institute of the Department of Atomic Energy,
Government of India, and a Deemed University)

सर्वेक्षण संख्या 36 / पी, गोपनपल्ली गांव, सेरिलिंगमपल्ली मंडल, रंगारेड्डी जिला, हैदराबाद - 500 046
36/P, Gopanpally Village, Serilingampally Mandal, Ranga Reddy District, Hyderabad - 500 046

SECTION-VI

ANNEXURES

ANNEXURE I

FORM OF PERFORMANCE GUARANTEE (BY BANK GUARANTEE)

1. In consideration of the TIFR-Hyderabad, Hyderabad having agreed under the terms and conditions of Letter of Intent / Agreement No..... dated..... made between and..... (Here in after..... called "the said Contractor(s)" for the work (Here in after called "the said Letter of Intent / Agreement") having agreed to production of a irrevocable bank Guarantee for Rs..... (Rupees only), as a security / guarantee from the contractor(s) for compliance of his obligations in accordance with the terms and conditions in the said agreement, we(Indicate the name of the Bank) (hereinafter referred to as "the Bank") Here by undertake to pay to TIFR an amount not exceeding Rs. (Rs only) on demand by TIFR.
2. We..... (indicate the name of Bank) do hereby undertake to pay the amounts due and payable under this guarantee without any demur, merely on a demand from TIFR stating that the amount claimed is required to meet the recoveries due or likely to be due from the said Contractor(s). Any such demand made on the bank shall be conclusive as regards the amount due and payable by the Bank under this guarantee. However, our liability under this guarantee shall be restricted to an amount not exceeding Rs..... (Rupees..... only).
3. We, the said bank, further undertake to pay to TIFR any money so demanded notwithstanding any dispute or disputes raised by the Contractor(s) in any suit or proceeding pending before any Court or Tribunal relating thereto, our liability under this present being absolute and unequivocal. The payment made by us under this bond shall be a valid discharge of our liability for payment thereunder and the Contractor(s) shall have no claim against us for making such payment.
4. We (indicate the name of Bank) further agree that the guarantee herein contained shall remain in full force and effect during the period that would be taken for the performance of the said Agreement and that it shall continue to be enforceable till all the dues of TIFR under or by virtue of the said Agreement have been fully paid and its claims satisfied or discharged or till Engineer-in-charge on behalf of the TIFR certifies that the terms and conditions of the said Agreement have been fully and properly carried out by the said Contractor(s) and accordingly discharges this guarantee.
5. We (indicate the name of Bank) further agree with TIFR that TIFR shall have the fullest liberty without our consent and without affecting in any manner our obligations hereunder to vary any of the terms and conditions of the said Agreement or to extend time of performance by the said Contractor(s) from time to time or to postpone for any time or from time to time any of the powers exercisable by TIFR against the said Contractor(s) and to forbear or enforce any of the terms and conditions relating to the said Agreement and we shall not be relieved from our liability by reason of any such variation, or extension being granted to the said Contractor(s) or for any forbearance, act of omission on the part of TIFR or any indulgence by TIFR to the said Contractor(s) or by any such matter or thing whatsoever which under the law relating to sureties would, but for this provision, have effect of so relieving us.
6. This guarantee will not be discharged due to the change in the constitution of the Bank or the Contractor(s).
7. We..... (indicate the name of Bank) lastly undertake not to revoke this guarantee except with the previous consent of TIFR in writing.
8. This guarantee shall be valid up to, unless extended on demand. Notwithstanding anything mentioned above, our liability against this guarantee is restricted to Rs (Rupees only) and unless a claim in writing is lodged with us within six months of the date of expiry or the extended date of expiry of this guarantee, all our liabilities under this guarantee shall stand discharged.

Signed and sealed

Dated the day of..... for..... (indicate the name of Bank) *(Note: The Letter of Intent shall form part of the Agreement)



टाटा मूलभूत अनुसंधान संस्थान
TATA INSTITUTE OF FUNDAMENTAL RESEARCH
भारत सरकार के परमाणु ऊर्जा विभाग की स्वायत्त संस्था एवं समविश्वविद्यालय
(An Autonomous Institute of the Department of Atomic Energy,
Government of India, and a Deemed University)

सर्वेक्षण संख्या 36 / पी, गोपनपल्ली गांव, सेरिलिंगमपल्ली मंडल, रंगारेड्डी जिला, हैदराबाद - 500 046
36/P, Gopanpally Village, Serilingampally Mandal, Ranga Reddy District, Hyderabad - 500 046

ANNEXURE II

UNDERTAKING BY THE TENDERER

I / We have read and examined the Tender document including terms & conditions, specifications, Schedule of quantities, drawings and designs, general rules & directions, General Conditions of Contract, Special Conditions of Contract and all relevant other documents, publications and rules referred to in the Conditions of Contract and all other contents in the tender documents for the work.

I / We, hereby tender for execution of the work specified for the TIFR-Hyderabad, Hyderabad within the time specified and in accordance with all respects with the specifications, designs, drawings and instructions in writing.

We agree to keep the tender open for seventy five (75) days from the last date of its submission and not to make any modifications in its terms and conditions. A sum of Rs..... has been deposited in cash / receipt treasury challan / deposit at call receipt of scheduled bank / fixed deposit receipt of scheduled bank / demand draft of a scheduled bank / Bank Guarantee issued by a Scheduled Bank as earnest money. If I / we, fail to furnish the prescribed performance guarantee within prescribed period, I / we agree that the said TIFR-Hyderabad, Hyderabad or its authorized officer shall without prejudice to any other right or remedy, be at liberty to forfeit the said earnest money absolutely. Further, if I / we fail to commence work as specified, I / we agree that the TIFR-Hyderabad, Hyderabad shall without prejudice to any other right or remedy available in law, be at liberty to forfeit the said earnest money and the performance guarantee absolutely, otherwise the said earnest money shall be retained by TIFR- Hyderabad, Hyderabad towards security deposit to execute all the works referred to in the tender documents upon the terms and conditions contained or referred to therein.

Further, I / We agree that in case of forfeiture of earnest money or both Earnest Money & Performance Guarantee as aforesaid, I / We shall be debarred for participation in the re-tendering process of the work.

I / We hereby declare that I / We shall treat the tender documents, drawings and other records connected with the work as secret / confidential documents and shall not communicate information derived there-from to any person other than a person to whom I / We am / are authorized to communicate the same or use the information in any manner prejudicial to the safety of the State.

Seal & Signature of Contractor Postal Address

Dated

Witness Address Occ



टाटा मूलभूत अनुसंधान संस्थान
TATA INSTITUTE OF FUNDAMENTAL RESEARCH
भारत सरकार के परमाणु ऊर्जा विभाग की स्वायत्त संस्था एवं समविश्वविद्यालय
(An Autonomous Institute of the Department of Atomic Energy,
Government of India, and a Deemed University)
सर्वेक्षण संख्या 36 / पी, गोपनपल्ली गांव, सेरिलिंगमपल्ली मंडल, रंगारेड्डी जिला, हैदराबाद - 500 046
36/P, Gopanpally Village, Serilingampally Mandal, Ranga Reddy District, Hyderabad - 500 046

ANNEXURE-III

CERTIFICATE OF LOCAL CONTENT

***We [name of manufacturer] hereby confirm in respect of quoted item(s) that local Content is equal to or more than 50% and come under 'Class-I Local Supplier' Category. As being 'Class-I Local Supplier', we are eligible for Purchase Preference under 'Make in India' Policy vide Gol Order No.P-45021/2/2017-PP (B.E.-II) dated 15.06.2017 (subsequently revised vide orders dated 28.05.2018, 29.05.2019 and 04.06.2020)**

OR

***We [name of manufacturer] hereby confirm in respect of quoted items(s) that Local Content is more than 20% but less than 50% and come under 'Class-II Local Supplier' Category.**

The details of the location (s) at which the local value addition made is / are under:

1.
2.

Date:

Seal & Signature of the Bidder

NOTE:

Self-certification that the item offered meets the minimum local content (as above) giving details of the location(s) at which the local value addition is made in case the bidder wishes to avail the benefits under the make in India policy, if applicable.

In cases of procurement for a value in excess of Rs.10 crores, the local supplier shall be required to provide a certificate from the statutory auditor or cost auditor of the company (in the case of companies) or from a practicing cost accountant or practicing chartered accountant (in respect of suppliers other than companies) giving the percentage of local content to avail the benefits under the make in India policy, if applicable.



टाटा मूलभूत अनुसंधान संस्थान
TATA INSTITUTE OF FUNDAMENTAL RESEARCH
भारत सरकार के परमाणु ऊर्जा विभाग की स्वायत्त संस्था एवं समविश्वविद्यालय
(An Autonomous Institute of the Department of Atomic Energy,
Government of India, and a Deemed University)
सर्वेक्षण संख्या 36 / पी, गोपनपल्ली गांव, सेरिलिंगमपल्ली मंडल, रंगारेड्डी जिला, हैदराबाद - 500 046
36/P, Gopanpally Village, Serilingampally Mandal, Ranga Reddy District, Hyderabad - 500 046

ANNEXURE-IV

TECHNICAL DATA SHEET-AIR COOLED CHILLER

S.No	PARAMETER	DETAILS
1.0	GENERAL:	
1.1	Manufacturer	
1.2	Country of Origin	
1.3	Model	
1.4	Nominal Capacity (TR)	
1.5	Capacity at specified conditions (TR)	
1.6	Refrigerant	
1.7	Dimensions (mm)	
1.8	Operating Weight (Kg.)	
1.9	Refrigerant Qty. (Kg.)	



टाटा मूलभूत अनुसंधान संस्थान
TATA INSTITUTE OF FUNDAMENTAL RESEARCH
भारत सरकार के परमाणु ऊर्जा विभाग की स्वायत्त संस्था एवं समविश्वविद्यालय
(An Autonomous Institute of the Department of Atomic Energy,
Government of India, and a Deemed University)
सर्वेक्षण संख्या 36 / पी, गोपनपल्ली गांव, सेरिलिंगमपल्ली मंडल, रंगारेड्डी जिला, हैदराबाद - 500 046
36/P, Gopanpally Village, Serilingampally Mandal, Ranga Reddy District, Hyderabad - 500 046

1.10	Microprocessor Panel / Electro mechanical panel	
1.11	BMS Protocol	
1.12	Type of starter	
1.13	Noise Level (dB A) @ 3 mt. distance	
1.14	Type of temperature controller	
2	POWER CONSUMPTION DETAILS:	
2.1	AT AHRI CONDITIONS:	
	IKW / TR at 100% (IKW/TR)	
	IKW / TR at 75% (IKW/TR)	
	IKW / TR at 50% (IKW/TR)	
	IKW / TR at 25% (IKW/TR)	
	COP at 100%	



टाटा मूलभूत अनुसंधान संस्थान
TATA INSTITUTE OF FUNDAMENTAL RESEARCH
भारत सरकार के परमाणु ऊर्जा विभाग की स्वायत्त संस्था एवं समविश्वविद्यालय
(An Autonomous Institute of the Department of Atomic Energy,
Government of India, and a Deemed University)
सर्वेक्षण संख्या 36 / पी, गोपनपल्ली गांव, सेरिलिंगमपल्ली मंडल, रंगारेड्डी जिला, हैदराबाद - 500 046
36/P, Gopanpally Village, Serilingampally Mandal, Ranga Reddy District, Hyderabad - 500 046

	IPLV (IKW/TR)	
2.2	AT TENDER CONDITIONS WITH AHRI RELIEF:	
	IKW / TR at 100% (IKW/TR) @ 106 deg. F	
	IKW / TR at 75% (IKW/TR) @ 86.9 deg. F	
	IKW / TR at 50% (IKW/TR) @ 67.8 deg. F	
	IKW / TR at 25% (IKW/TR) @ 55.0 deg. F	
	COP at 100%	
	NPLV (IKW/TR)	
3	ISOLATOR AND CURRENT	
	Full Load Current (Amp)	
	Starting Current (Amp)	



टाटा मलभूत अनुसंधान संस्थान
TATA INSTITUTE OF FUNDAMENTAL RESEARCH
भारत सरकार के परमाणु ऊर्जा विभाग की स्वायत्त संस्था एवं समविश्वविद्यालय
(An Autonomous Institute of the Department of Atomic Energy,
Government of India, and a Deemed University)
सर्वेक्षण संख्या 36 / पी, गोपनपल्ली गांव, सेरिलिंगमपल्ली मंडल, रंगारेड्डी जिला, हैदराबाद - 500 046
36/P, Gopanpally Village, Serilingampally Mandal, Ranga Reddy District, Hyderabad - 500 046

		Locked Rotor Current (Amp)	
		Isolator Capacity (A)	
		Number of isolators	
4		COMPRESSOR:	
4.1		Type of compressor	
4.2		No. of circuits	
4.3		No. of compressors	
4.4		Type of loading and steps	
4.5		Type of unloading and steps	
4.6		Type of starter for the compressor	
5		EVAPORATOR:	



टाटा मूलभूत अनुसंधान संस्थान
TATA INSTITUTE OF FUNDAMENTAL RESEARCH
भारत सरकार के परमाणु ऊर्जा विभाग की स्वायत्त संस्था एवं समविश्वविद्यालय
(An Autonomous Institute of the Department of Atomic Energy,
Government of India, and a Deemed University)
सर्वेक्षण संख्या 36 / पी, गोपनपल्ली गांव, सेरिलिंगमपल्ली मंडल, रंगारेड्डी जिला, हैदराबाद - 500 046
36/P, Gopanpally Village, Serilingampally Mandal, Ranga Reddy District, Hyderabad - 500 046

5.1	Type of construction	
5.2	Fouling Factor (British Units)	
5.3	Chilled Water Temp. in deg. F	
5.4	Chilled Water Temp. out deg. F	
5.5	Water Flow (USGPM) at NPLV	
5.6	Water Pressure Drop (ft of water)	
5.7	Water Connection Size (mm)	
5.8	No. of passes on water side	
5.9	No. of circuits on refrigerant side	
6	CONDENSER:	
6.1	Type of condenser	
6.2	Air Quantity (Cfm)	



टाटा मूलभूत अनुसंधान संस्थान
TATA INSTITUTE OF FUNDAMENTAL RESEARCH
भारत सरकार के परमाणु ऊर्जा विभाग की स्वायत्त संस्था एवं समविश्वविद्यालय
(An Autonomous Institute of the Department of Atomic Energy,
Government of India, and a Deemed University)
सर्वेक्षण संख्या 36 / पी, गोपनपल्ली गांव, सेरिलिंगमपल्ली मंडल, रंगारेड्डी जिला, हैदराबाद - 500 046
36/P, Gopanpally Village, Serilingampally Mandal, Ranga Reddy District, Hyderabad - 500 046

6.3	No. of fans (no.)	
6.4	Type of fan	
6.5	Fan diameter (inches)	
6.6	Fan speed (RPM)	
6.7	Material of Fan Impeller	
6.8	Motor Rating of each fan motor (Kw)	
6.9	Class of Motor Protection	
6.10	Condenser Coil Face Area (Sq. mt.)	
6.11	No. of rows	
6.12	Fins / inch	
6.13	Type of starter for condenser fans	



टाटा मूलभूत अनुसंधान संस्थान
TATA INSTITUTE OF FUNDAMENTAL RESEARCH
भारत सरकार के परमाणु ऊर्जा विभाग की स्वायत्त संस्था एवं समविश्वविद्यालय
(An Autonomous Institute of the Department of Atomic Energy,
Government of India, and a Deemed University)
सर्वेक्षण संख्या 36 / पी, गोपनपल्ली गांव, सेरिलिंगमपल्ली मंडल, रंगारेड्डी जिला, हैदराबाद - 500 046
36/P, Gopanpally Village, Serilingampally Mandal, Ranga Reddy District, Hyderabad - 500 046

TECHNICAL DATA SHEET-PUMPS

S.No	PARAMETER	DETAILS
1	Make	
2	Model	
3	Type of pump	
4	Capacity (USGPM)	
5	Head (feet)	
6	Speed (RPM)	
7	BHP (Kw)	
8	Efficiency (%)	
9	Casing Material	
10	Impeller Material	
11	Seal	



टाटा मलभूत अनुसंधान संस्थान
TATA INSTITUTE OF FUNDAMENTAL RESEARCH
भारत सरकार के परमाणु ऊर्जा विभाग की स्वायत्त संस्था एवं समविश्वविद्यालय
(An Autonomous Institute of the Department of Atomic Energy,
Government of India, and a Deemed University)
सर्वेक्षण संख्या 36 / पी, गोपनपल्ली गांव, सेरिलिंगमपल्ली मंडल, रंगारेड्डी जिला, हैदराबाद - 500 046
36/P, Gopanpally Village, Serilingampally Mandal, Ranga Reddy District, Hyderabad - 500 046

12	Motor (Kw)	
13	Type of Motor	
14	Speed of Motor	
15	Make of the motor	
16	Efficiency rating of the motor	
17	Efficiency of the motor (%)	
18	Overall Dimensions (mm)	
19	Operating Weight (Kg)	
	VFD	
1	Make	
2	Model	
3	Type	
4	Power Rating	
5	IP Rating	
6	Type of Filters	



टाटा मूलभूत अनुसंधान संस्थान
TATA INSTITUTE OF FUNDAMENTAL RESEARCH
भारत सरकार के परमाणु ऊर्जा विभाग की स्वायत्त संस्था एवं समविश्वविद्यालय
(An Autonomous Institute of the Department of Atomic Energy,
Government of India, and a Deemed University)
सर्वेक्षण संख्या 36 / पी, गोपनपल्ली गांव, सेरिलिंगमपल्ली मंडल, रंगारेड्डी जिला, हैदराबाद - 500 046
36/P, Gopanpally Village, Serilingampally Mandal, Ranga Reddy District, Hyderabad - 500 046

7	Harmonics w.r.t. Voltage	
8	Harmonics w.r.t. Current	
9	BMS protocol third party integration	



टाटा मलभूत अनुसंधान संस्थान
TATA INSTITUTE OF FUNDAMENTAL RESEARCH
भारत सरकार के परमाणु ऊर्जा विभाग की स्वायत्त संस्था एवं समविश्वविद्यालय
(An Autonomous Institute of the Department of Atomic Energy,
Government of India, and a Deemed University)
सर्वेक्षण संख्या 36 / पी, गोपनपल्ली गांव, सेरिलिंगमपल्ली मंडल, रंगारेड्डी जिला, हैदराबाद - 500 046
36/P, Gopanpally Village, Serilingampally Mandal, Ranga Reddy District, Hyderabad - 500 046

ANNEXURE-V

CHILLER LAYOUT DRAWING





टाटा मलभूत अनुसंधान संस्थान
TATA INSTITUTE OF FUNDAMENTAL RESEARCH
भारत सरकार के परमाणु ऊर्जा विभाग की स्वायत्त संस्था एवं समविश्वविद्यालय
(An Autonomous Institute of the Department of Atomic Energy,
Government of India, and a Deemed University)
सर्वेक्षण संख्या 36 / पी, गोपनपल्ली गांव, सेरिलिंगमपल्ली मंडल, रंगारेड्डी जिला, हैदराबाद - 500 046
36/P, Gopanpally Village, Serilingampally Mandal, Ranga Reddy District, Hyderabad - 500 046

CHILLER-SCHEMATIC DRAWING

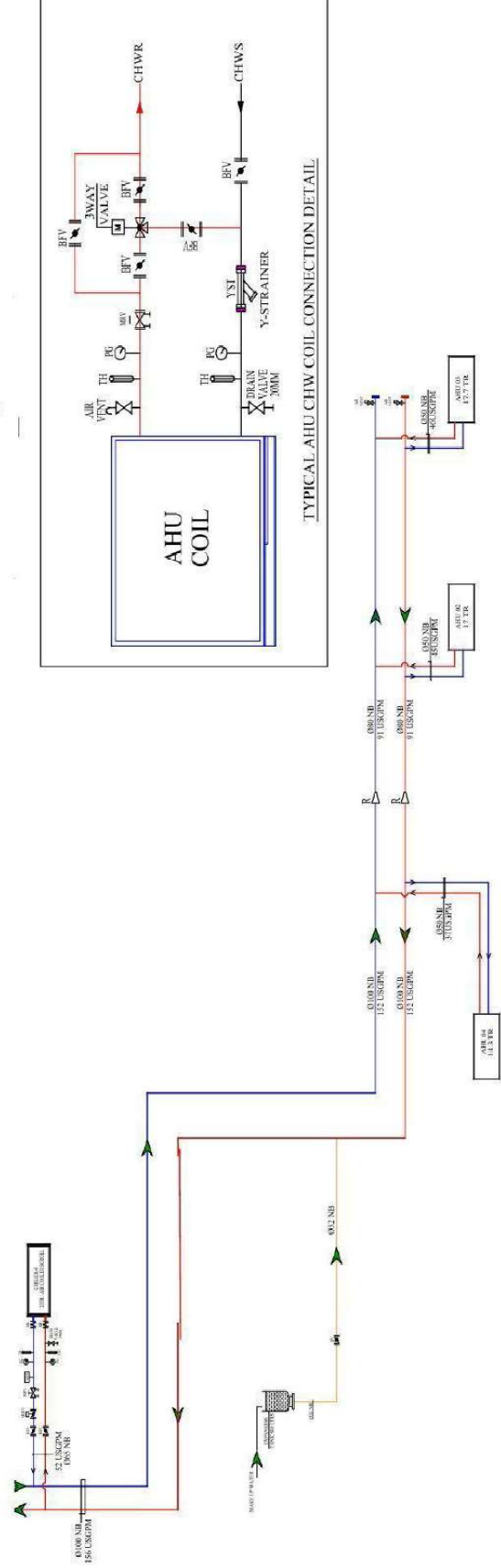



टाटा मूलभूत अनुसंधान संस्थान
TATA INSTITUTE OF FUNDAMENTAL RESEARCH
भारत सरकार के परमाणु ऊर्जा विभाग की स्वायत्त संस्था एवं समविश्वविद्यालय
(An Autonomous Institute of the Department of Atomic Energy,
Government of India, and a Deemed University)

सर्वेक्षण संख्या 36 / पी, गोपनपल्ली गांव, सेरिलिंगमपल्ली मंडल, रंगारेड्डी जिला, हैदराबाद - 500 046
36/P, Gopanpally Village, Serilingampally Mandal, Ranga Reddy District, Hyderabad - 500 046

SECTION-VII

FINANCIAL BID

INVITATION OF BIDS FOR

Supply, Installation, Testing and commissioning of High side and Low side HVAC works for Animal Facility in Hanger-02, TIFR, Survey No. 36/P, Gopanpally (Village), Serilingampally (Mandal), Ranga Reddy Dist., Hyderabad-500046.

PART II

FINANCIAL BID



टाटा मूलभूत अनुसंधान संस्थान
TATA INSTITUTE OF FUNDAMENTAL RESEARCH
भारत सरकार के परमाणु ऊर्जा विभाग की स्वायत्त संस्था एवं समविश्वविद्यालय
(An Autonomous Institute of the Department of Atomic Energy,
Government of India, and a Deemed University)
सर्वेक्षण संख्या 36 / पी, गोपनपल्ली गांव, सेरिलिंगमपल्ली मंडल, रंगारेड्डी जिला, हैदराबाद - 500 046
36/P, Gopanpally Village, Serilingampally Mandal, Ranga Reddy District, Hyderabad - 500 046

S.No	Description	Unit	Qty(A)	Rate(B)	Total Amount(C=A*B)
1	Supply, Installation, Testing and Commissioning of Factory-Packaged and Tested of 60 TR Air cooled liquid chillers. Chiller with Multi / single scroll Compressor/Screw with Hermetically sealed type with motor, suitable for 400±10% volts, 50 cycles AC supply. Independent Refrigerant Circuit with R-410A/ R-134A refrigerant with compressor, Shell and Tube/ PHE Evaporator including Safety Switch, Pressure Transducer, High Pressure Switch, Compressor Suction and Discharge Shut Off Valves, Condenser Coil, Condenser fan motor, Electronic/ Thermostatic Expansion Valve as per OEM. The following capacities shall be delivered capacities under ambient temperature of 45 deg. C and chilled water in and out temperatures of 10.5 / 5 deg. C. Chilled water out temperature of 5 deg. C is very important to maintain the required RH inside. Chillers shall be capable of operating under ambient temperatures of 50 deg. C. Chiller selection sheet shall be submitted along with the offer. Shall be capable of integrating with a third party BMS system. Necessary modbus RS 485 or Bacnet integrator shall be supplied and installed. All the parameters shall be shown and shall be coordinated with BMS vendor for integration with existing BMS system. Chillers shall be installed with necessary vibration isolators. 60 TR actual delivered capacity under above conditions. Necessary Computer selection with Model / catalogs to be submitted with quote for evaluation. The chiller package shall be BMS compatible. The control panel shall incorporate BMS integrator for complete integration of data of microprocessor panel with BMS as per the specifications. The chiller control panel should have provision to accept armoured cable or necessary cable boxes with flexible cables needs to be provided. Should include flow switches, victaulic couplings etc . Desired capacity to be at AHRI condition with minimum COP as per ECBC standard. Chiller should be AHRI Certified.	NOS	1		



टाटा मूलभूत अनुसंधान संस्थान
TATA INSTITUTE OF FUNDAMENTAL RESEARCH
 भारत सरकार के परमाणु ऊर्जा विभाग की स्वायत्त संस्था एवं समविश्वविद्यालय
 (An Autonomous Institute of the Department of Atomic Energy,
 Government of India, and a Deemed University)
 सर्वेक्षण संख्या 36 / पी, गोपनपल्ली गांव, सेरिलिंगमपल्ली मंडल, हैदराबाद - 500 046
36/P, Gopanpally Village, Serilingampally Mandal, Ranga Reddy District, Hyderabad - 500 046

		NOS'	2		
2	Supply, Installation, Testing and Commissioning of vertical inline chilled water pumps of 168 GPM @ 25 mt. head with mechanical seal, etc. (1 Working + 1 Standby).				
3	Supply, Installation, Testing and Commissioning of 100mm dia nominal sizes of chilled water piping above the ground floor (with necessary M.S channel supports, puff sadales clamps, vibrations isolators and fittings but excluding valves, strainers, gauges etc.) duly insulated with fire retardant quality expanded polystyrene moulded pipe section of density 20kg/cu. after a thick coat of cold setting adhesive (CPEX compound) wrapping with 500g polythene faced hessian and finally 0.63mm aluminum sheet complete with type 3 grade 1 roofing felt strip (as per IS: 1322 as amended up to date) at joints repairing etc. as per specifications and as required complete in all respect. Note: The pipes of sizes 150 mm Below shall be M.S.'C' class as per IS: 1239 and pipes sizes above 150 mm shall be welded black steel pipe heavy class as per IS: 3589. Pipe welding shall be carried out with valid 6G certified welders.	RMT	30		
4	Supply, Installation, Testing and Commissioning of 80mm dia nominal sizes of chilled water piping above the ground floor (with necessary M.S channel supports, puff sadales clamps, vibrations isolators and fittings but excluding valves, strainers, gauges etc.) duly insulated with fire retardant quality expanded polystyrene moulded pipe section of density 20kg/cu. after a thick coat of cold setting adhesive (CPEX compound) wrapping with 500g polythene faced hessian and finally 0.63mm aluminum sheet complete with type 3 grade 1 roofing felt strip (as per IS: 1322 as amended up to date) at joints repairing etc. as per specifications and as required complete in all respect. Note: The pipes of sizes 150 mm Below shall be M.S.'C' class as per IS: 1239. Pipe welding shall be carried out with valid 6G certified welders.	RMT	40		



टाटा मूलभूत अनुसंधान संस्थान
TATA INSTITUTE OF FUNDAMENTAL RESEARCH
 भारत सरकार के परमाणु ऊर्जा विभाग की स्वायत्त संस्था एवं समविश्वविद्यालय
 (An Autonomous Institute of the Department of Atomic Energy,
 Government of India, and a Deemed University)

सर्वेक्षण संख्या 36 / पी, गोपनपल्ली गांव, सेरिलिंगमपल्ली मंडल, रंगारेड्डी जिला, हैदराबाद - 500 046
36/P, Gopanpally Village, Serilingampally Mandal, Ranga Reddy District, Hyderabad - 500 046

5	<p>Supply, Installation, Testing and Commissioning of 65mm dia nominal sizes of chilled water piping above the ground floor (with necessary M.S channel supports,puff sadales clamps,vibrations isolators and fittings but excluding valves,strainers,gauges etc.)duly insulated with fire retardant quality expanded polystyrene moulded pipe section of density 20kg/cu. after a thick coat of cold setting adhesive(CPEX compound) wrapping with 500g polythene faced hessian and finally 0.63mm aluminum sheet complete with type3 grade 1 roofing feltstrip(as per IS:1322 as amended up to date) at joints repairing etc.as per specifications and as required complete in all respect. Note:The pipes of sizes 150 mm below shall be M.S.'C' class as per IS:1239.Pipe welding shall be carried out with valid 6G certified welders</p>	RMT	50		
6	<p>Supply, Installation, Testing and Commissioning of 50mm dia nominal sizes of chilled water piping above the ground floor (with necessary M.S channel supports,puff sadales clamps,vibrations isolators and fittings but excluding valves,strainers,gauges etc.)duly insulated with fire retardant quality expanded polystyrene moulded pipe section of density 20kg/cu. after a thick coat of cold setting adhesive(CPEX compound) wrapping with 500g polythene faced hessian and finally 0.63mm aluminum sheet complete with type3 grade 1 roofing feltstrip(as per IS:1322 as amended up to date) at joints repairing etc.as per specifications and as required complete in all respect. Note:The pipes of sizes 150 mm below shall be M.S.'C' class as per IS:1239.Pipe welding shall be carried out with valid 6G certified welders</p>	RMT	150		
7	<p>Supply, Installation, Testing and Commissioning of 32mm dia nominal sizes of chilled water piping above the ground floor (with necessary M.S channel supports,puff sadales clamps,vibrations isolators and fittings but excluding valves,strainers,gauges etc.)duly insulated with fire retardant quality expanded polystyrene moulded pipe section of density 20kg/cu. after a thick coat of cold setting adhesive(CPEX compound) wrapping with 500g polythene faced hessian and finally 0.63mm aluminum sheet complete with type3 grade 1 roofing feltstrip(as per IS:1322 as amended up to date) at joints repairing etc.as per specifications and as required complete in all respect.</p>	RMT	20		



टाटा मूलभूत अनुसंधान संस्थान
TATA INSTITUTE OF FUNDAMENTAL RESEARCH
 भारत सरकार के परमाणु ऊर्जा विभाग की स्वायत्त संस्था एवं समविश्वविद्यालय
 (An Autonomous Institute of the Department of Atomic Energy,
 Government of India, and a Deemed University)
 सर्वेक्षण संख्या 36 / पी, गोपनपल्ली गांव, सेरिलिंगम्पल्ली मंडल, रंगारेड्डी जिला, हैदराबाद - 500 046
36/P, Gopanpally Village, Serilingampally Mandal, Ranga Reddy District, Hyderabad - 500 046

	Note: The pipes of sizes 150 mm below shall be M.S.'C' class as per IS:1239. Pipe welding shall be carried out with valid 6G certified welders				
8	Supply, Installation, Testing and Commissioning of 50MM Dia Manual Balancing Valve with built in measuring facility with CI body flanged construction with EPDM coated disc with long pitch with protected outpipe insulation with matching flanges, gasket, bolt nuts, insulation, etc. Duly insulated to the same specifications as the connected piping. Pressure rating shall be PN 16.	NOS	3		
9	Supply, Installation, Testing and commissioning of 50MM Dia 3 way motorized Control Valve for chilled water application , having efficient flow characteristics with copper alloy metal gun body and disc must be copper alloy rod and bars EPDM diaphragm screw and unique connections. This includes smart actuator with provision of fail safe opening provision (manual operation button with lock) , Actuator should be provided with appropriate enclosure to protect from rain, with required supports and accessoires like flanges, bolts, nuts gaskets, pressure rating PN 25. It should have a provision of an auto closing module able to set the valve to Zero signal position when the AHU motor is stopped which includes integrating cables between AHU starter , Actuator and thermostat . Consider that the starters are having one no spare NC point. The control cable qty within 12 rmt per AHU to be included . Actuator Voltage either 24V AC/DC, control signal either 0-10 V DC or 4-20 ma. Vendor to submit the selection for approval. Necessary temperature controllers shall be provided for maintaining the required return air / exhaust air temperature.	NOS	3		
10	Supply, Installation, Testing and Commissioning of 100MM Dia Butterfly valve (Manual) with CI body SS Disc, Nitrile Rubber Seal O-Ring with matching flanges, bolt nuts, extended stem etc. Duly insulated to the same specifications as the connected piping. Pressure rating shall be PN 16.	NOS	6		
11	Supply, Installation, Testing and Commissioning of 50 MM Dia Butterfly valve (Manual) with CI body SS Disc, Nitrile Rubber Seal O-Ring with matching flanges, bolt nuts, extended stem etc. Duly insulated to the same specifications as the connected piping. Pressure rating shall be PN 16.	NOS	12		



टाटा मूलभूत अनुसंधान संस्थान
TATA INSTITUTE OF FUNDAMENTAL RESEARCH
भारत सरकार के परमाणु ऊर्जा विभाग की स्वायत्त संस्था एवं समविश्वविद्यालय
(An Autonomous Institute of the Department of Atomic Energy,
Government of India, and a Deemed University)

सर्वेक्षण संख्या 36 / पी, गोपनपल्ली गांव, सेरिंगम्पल्ली मंडल, रंगारेड्डी जिला, हैदराबाद - 500 046
36/P, Gopanpally Village, Serilingampally Mandal, Ranga Reddy District, Hyderabad - 500 046

12	Supply, Installation, Testing and Commissioning of 100MM Dia Y Strainers of Ductile CI Body flanged ends with SS strainer matching flanges, gasket, bolts nuts, insulation, etc. Duly insulated to the same specifications as the connected piping. Pressure rating shall be PN 16.	NOS	2		
13	Supply, Installation, Testing and Commissioning of 50MM Dia Y Strainers of Ductile CI Body flanged ends with SS strainer matching flanges, gasket, bolts nuts, insulation, etc. Duly insulated to the same specifications as the connected piping. Pressure rating shall be PN 16.	NOS	3		
14	Supply, Installation, Testing and Commissioning of 100MM Dia dual plate non return valve with matching flanges, gasket, bolts nuts, insulation, etc. Duly insulated to the same specifications as the connected piping. Pressure rating shall be PN 16.	NOS	2		
15	Supply, Installation, Testing and Commissioning of 100MM Dia flexible connections at inlet and outlet of coolers and pumps with matching flanges, gaskets, control unit, bolt nuts, etc. Pressure rating shall be PN 16.	NOS	2		
16	Supply, installation, testing and commissioning of 50MM Dia globe valves with flanges/nipples, supports, bolt nuts. Valve dia shall be made of gun metal with screw ends. And the rotating ball shall be made of SS. Insulation shall be similar to insulation of hot water piping insulation. Duly insulated to the same specifications as the connected piping. Valves shall be of PN 16 rating	NOS	3		
17	Supply Installation, Testing and Commissioning of 4 inch dia dial type thermometers with copper thermo well mounting box, extend capillary, etc. Thermometer shall be of complete SS. All internals, casing, etc. Pressure rating shall be PN 16.	NOS	12		
18	Supply, Installation, Testing and Commissioning of 4 inch dia dial type pressure gauge with isolating ball valve with insulation. Pressure gauge shall be of complete SS. All internals, casing, etc. Pressure rating shall be PN 16.	NOS	12		
19	Supply, Installation, Testing and Commissioning of 32MM Dia Ball valve for equipment connections, drain with necessary fitting, threaded nipples, dummy caps, etc. Pressure rating shall be PN 16.	NOS	8		



टाटा मूलभूत अनुसंधान संस्थान
TATA INSTITUTE OF FUNDAMENTAL RESEARCH
 भारत सरकार के परमाणु ऊर्जा विभाग की स्वायत्त संस्था एवं समविश्वविद्यालय
 (An Autonomous Institute of the Department of Atomic Energy,
 Government of India, and a Deemed University)

सर्वेक्षण संख्या 36 / पी, गोपनपल्ली गांव, सेरिलिंगमपल्ली मंडल, रंगारेड्डी जिला, हैदराबाद - 500 046
36/P, Gopanpally Village, Serilingampally Mandal, Ranga Reddy District, Hyderabad - 500 046

		NOS	10		
20	Supply, Installation, Testing and Commissioning of 5/8 Inches of auto air vents with isolating ball valves.	NOS	10		
21	Supply, installation, testing and commissioning of HDPE expansion tank of 500 lit. with fresh water connection, drain, overflow, float valve, etc. for hot water. Shall be installed in the Plant room with necessary supports, connections like inlet, outlet, overflow, float valve, other necessary valves, etc.	NOS	1		
22	Supply, Fabrication, Installation, Testing and Commissioning of structural supports with MS channels, angles, pipes, etc. with one coat of primer and two coats of final enamel paint. This item is only for support near the chillers and near the AHUs, Makeup tank. All other supports shall be part of the respective item.	KGS	1000		
23	Chemical flushing of chilled water & with two levels of water flush & chemical flush & passivation with chemical before the system is charged. Chemical flush to be carried out after final flush with water which devoid any debris & turbid content in water. [Limited to new piping only]	LOT	1		
24	Dismantling of portion of AHU-02 and removing of existing stand by DX cooling coils and supply , installation, testing & commissioning of 20TR @ 1750 CFM new 8 row chilled water coils with copper tubes aluminum hydrophilic coated fins and re installation of the AHU panels as required. This is to be carried out without damaging the existing working DX cooling coil. 100% Fresh air coil to be selected for Hyderabad conditions. Coil selection shall be submitted for review and approval.	SET	1		
25	Dismantling of portion of AHU-03 and removing of existing stand by DX cooling coils and supply , installation, testing & commissioning of 25 TR @ 2500 CFM new 8 row chilled water coils with copper tubes aluminum hydrophilic coated fins and re installation of the AHU panels as required. This is to be carried out without damaging the existing working DX cooling coil. 100% Fresh air coil to be selected for Hyderabad conditions. Coil selection shall be submitted for review and approval.	SET	1		



टाटा मूलभूत अनुसंधान संस्थान
TATA INSTITUTE OF FUNDAMENTAL RESEARCH
भारत सरकार के परमाणु ऊर्जा विभाग की स्वायत्त संस्था एवं समविश्वविद्यालय
(An Autonomous Institute of the Department of Atomic Energy,
Government of India, and a Deemed University)
सर्वेक्षण संख्या 36 / पी, गोपनपल्ली गांव, सेरिंगम्पल्ली मंडल, रंगारेड्डी जिला, हैदराबाद - 500 046
36/P, Gopanpally Village, Serilingampally Mandal, Ranga Reddy District, Hyderabad - 500 046

26	Dismantling of portion of AHU-04 and removing of existing stand by DX cooling coils and supply , installation, testing & commissioning of 17TR @ 1500 CFM new 8 row chilled water coils with copper tubes aluminum hydrophilic coated fins and re installation of the AHU panels as required. This is to be carried out without damaging the existing working DX cooling coil. 100% Fresh air coil to be selected for Hyderabad conditions. Coil selection shall be submitted for review and approval.	SET	1		
Sub-Total (D)					
GST 18% (E)					
GRAND TOTAL (D+E)					
Total Amount in Words Rs					
.....Only					



टाटा मूलभूत अनुसंधान संस्थान
TATA INSTITUTE OF FUNDAMENTAL RESEARCH
भारत सरकार के परमाणु ऊर्जा विभाग की स्वायत्त संस्था एवं समविश्वविद्यालय
(An Autonomous Institute of the Department of Atomic Energy,
Government of India, and a Deemed University)
सर्वेक्षण संख्या 36 / पी, गोपनपल्ली गांव, सेरिलिंगमपल्ली मंडल, रंगारेड्डी जिला, हैदराबाद - 500 046
36/P, Gopanpally Village, Serilingampally Mandal, Ranga Reddy District, Hyderabad - 500 046

NOTE:

1. Please mention the item rate in figures and also in words.
2. Rates are all inclusive of profit, Transport, Loading & Unloading, Shifting Taxes, Etc.
3. TIFR, Hyderabad has the right to delete any of the above items from scope of work or may increase/reduce quantities as per its requirement during execution of work. No claim or compensation for such deletion/increase/decrease will be accepted/paid to the contractor. Payment will be made as per actual quantities executed at tender rates.
4. Manufacturer's warranty of respective supply items to be provided.
5. For any above item quantity exceeding more than 10% of projected qty, contractor shall take prior approval from TIFR Engineer in writing.
6. For any deviating items, the contractor shall take prior approval from TIFR Engineer In charge with proper rate analysis.