



Telephone:+91-40-20203009	Date: 06.02.2024
Website : www.tifrh.res.in	Email: krishnaae@tifrh.res.in

PUBLIC TENDER
(TWO PART TENDER) for the following Works:

Annual Maintenance Contract for Operation & Maintenance of water supply, sewage system and carpentry works on 24x7 Basis on all days at TIFR, Survey No. 36/P, Gopanapally (Village), Serilingampally (Mandal), RR Dist., Hyderabad-500046.	
Tender No.	TIFR/PD/CF23-198/231608
Type of Tender	Two Part Tender (Part-I: Technical Bid and Part- II: Price Bid)
Estimated Cost	Rs. 46,99,000/-
Cost of EMD	Rs.93,980/- Demand Draft to be drawn in favor of“TIFR Center for Interdisciplinary Sciences”, Payable at Hyderabad (To be enclosed with the Technical Bid Part – I).
Pre bidding meeting & Time	12.02.2024 at 11:00 Hrs.
Last Date for Submission of Tender	21.02.2024 by 13:00 Hrs.
Date of Opening Bids(Only Part-I: Technical Bid)	21.02.2024 at 15:00 Hrs.
Tender Fee	Rs.500/-(Demand Draft to be drawn in favor of“TIFR Centre for Interdisciplinary Sciences “Payable at Hyderabad (To be enclosed with the Technical Bid Part –I).

- In case the Part “I” and Part “II” bids are not sealed in separate envelopes the tender will be rejected.
- The technical bid should not contain any indication of the price.
- The Technical Bid received without payment of tender fees and EMD shall be summarily rejected.



TATA INSTITUTE OF FUNDAMENTAL RESEARCH
(Autonomous Institution of the Department of Atomic Energy, Government of India)
Survey No.36/P, Gopanpally Village, Serilingampally Mandal, Ranga Reddy
District, Hyderabad-500046, Telangana

Contacts: Mr. Krishna. Tel: 040-20203009 / 3003 for any commercial and Mr.P Kasi Vishwanath Tel: 040-20203007 for technical clarifications. Terms clarifications mentioned in the tender.

Sealed tenders are invited for AMC for the aforesaid works from contractors having similar work experience in reputed Research Institutions, Universities, Central Government/Public Sector Undertaking, Private Laboratories, Multinational Companies, etc. Interested contractors who are satisfying prequalification criteria stipulated by TIFR-Hyderabad shall only submit their bids. For further details and any clarification on the tender you may please contact Engineer (E), Survey No.36/P, Gopanpally Village, Serilingampally Mandal, Ranga Reddy District, Hyderabad-500046.

Last date for submission of the tender is 21.02.2024 by 13:00 Hrs.

A handwritten signature in black ink, appearing to read 'Rajasekhar R.', is positioned above the printed name and title.

(Rajasekhar. R)
Head-Technical Services



TENDER DOCUMENT

Annual Maintenance Contract for Operation & Maintenance of water supply, sewage system and carpentry works on 24x7 Basis on all days at TIFR, Survey No. 36/P, Gopanpally (Village), Serilingampally (Mandal), RR Dist., Hyderabad-500046.

NAME OF THE TENDERER: -----

ADDRESS: -----

Last date of submission of the tender: On or before 21.02.2024 by 13:00 Hrs.



TECHNICAL BID

VOLUME-I

Annual Maintenance Contract for Operation & Maintenance of water supply, sewage system and carpentry works on 24x7 Basis on all days at TIFR, Survey No. 36/P, Gopanpally (Village), Serilingampally (Mandal), RR Dist., Hyderabad-500046.

INDEX

SECTION	Contents	Page No
SECTION I	Notice Inviting Tender	6-7
SECTION II	Forwarding Letter	8
SECTION III	Application Form	9-14
SECTION IV	Eligibility Criteria	15-16
SECTION V	Scope of work	17-31
SECTION VI	General Terms & Conditions	32—36
SECTION VII	Special Conditions of contract	37-38
SECTION VIII	Appendix to form of tender	39
SECTION IX	Price Bid	40-46

SECTION-I

NOTICE INVITING TENDER

Notice Inviting Tender

Applications are invited in the prescribed format for Annual Maintenance Contract for Operation & Maintenance of water supply, sewage system and carpentry works on 24x7 Basis on all days at TIFR, Survey No. 36/P, Gopanpally (Village), Serilingampally (Mandal), RR Dist., Hyderabad-500046.

The Contractors who are having their office at Hyderabad and registered/empaneled with Premier Research Institutes, Universities, IITs, Research Laboratories, Central/State Govt./ Govt. Undertakings Institutes, etc. having experience in executing similar nature of works may apply in the prescribed form as given. The Eligibility Criteria, Scope of Work, General Terms & Conditions and special conditions of contract are given in tender.

Bidders may download the document from TIFR-Hyderabad website (www.tifrh.res.in). Completed applications duly filled and **Earnest Money Deposit (EMD) of Rs.93,980/- and receipt of tender cost of Rs. 500/-** shall be enclosed in a Sealed cover- 1 and the same shall contain the following document duly signed by tenderer:

- i) Forwarding letter on letterhead of the firm/contractor.
- ii) Application Form.
- iii) Copy of eligibility criteria.
- iv) Copy of scope of work.
- v) Copy of general terms and conditions.
- vi) Copy of special conditions of contract
- vii) Copies of certificates from clients regarding satisfactory performance and duration of services rendered. Original certificates are required to be produced for verification as and when needed.
- viii) Copies of Balance Sheet and Profit & Loss Account statement for last 3 years ending March 31, 2023.
- ix) Copy of registration certificate(s).
 - i. Registrar of firms
 - ii. Central/State Labour license
 - iii. EPF
 - iv. ESI
 - v. GST
 - vi. PAN

The total amount as per the format given duly signed shall be enclosed in a sealed envelope marked as cover -2 (Price Bid).



Both the covers 1 & 2 should be enclosed in cover – 3 superscribing “Annual Maintenance Contract for Operation & Maintenance of water supply, sewage system and carpentry works on 24x7 Basis on all days” at TIFR, Survey No. 36/P, Gopanpally (Village), Serilingampally (Mandal), RR Dist., Hyderabad-500046 **on or before 13.00 Hrs. on 21.02.2024.**

Bidders shall note that Cover-1 containing Technical Bid Volume-I (ie Pre-qualification Bid)] shall be opened at 15.00 Hrs on the same day. The date and time of opening the Cover-2 [Price Bid-Volume II] of the pre-qualified vendors would be intimated separately. The price bids (Cover-2) of the prequalified vendors will only be considered for the opening and further processing.

Tender not accompanied by EMD and Tender Fee Receipt shall be summarily rejected. EMD shall not bear any interest and this amount shall be forfeited in the event of refusal or delay on the part of the tenderer to sign and execute the contract, in case his tender is accepted. The EMD of unsuccessful bidders shall be returned after finalization of tender. The cost of tender is non-refundable. The EMD of the successful bidder shall be adjusted in security deposit.

The rates quoted shall be valid for 90 days from the date of Technical Bid opening. The rate for providing the maintenance services shall be quoted as per the enclosed format given in price bid & shall be inclusive of all taxes, duties, works contract tax etc. However, GST will be payable extra.

If any information furnished by the applicant is found to be incorrect at a later date, the bidder shall be liable to be debarred from tendering / taking up the work in TIFR- Hyderabad. The TIFR-Hyderabad reserves the right to verify the particulars furnished by the applicant independently.

The TIFR-Hyderabad reserves the right to reject any application without assigning any reason and to restrict the list to any number deemed suitable by it, if too many applications are received satisfying the basic pre-qualification criteria.

Sd/-
Head-Technical Services



SECTION-II

FORWARDING LETTER

(To be submitted on firm/contractor's letterhead)

No.....

Date:

To
HEAD-TECHNICAL SERVICES,
TIFR-Hyderabad,
Survey No. Survey No. 36/P, Gopanpally Village,
Serilingampally Mandal,
Ranga Reddy District, Hyderabad 500046.

Dear Sir,

Annual Maintenance Contract for Operation & Maintenance of water supply, sewage system and carpentry works on 24x7 Basis on all days at TIFR, Survey No. 36/P, Gopanpally (Village), Serilingampally (Mandal), RR Dist., Hyderabad-500046.

With reference to your Notice for AMC for 24X7 basis operation and maintenance of Plumbing, Carpentry Works , Operation & Maintenance of STP plant, I am / we are pleased to offer myself / ourselves for undertaking above work in your esteemed organization. In submission of this offer, we confirm that

- i) We have not made any misleading or false representation in the forms, statements and attachments in proof of the qualification requirements.
- ii) We do not have records of poor performance such as abandoning the work, not properly completing the contract, inordinate delays in completion, litigation history or financial failures etc.
- iii) Business has never been banned by the Central / State Government Department/ Public Sector Undertaking or Enterprise of Central / State Government.
- iv) We have submitted all the supporting documents and furnished the relevant details as per prescribed format.
- v) The information and documents submitted with the tender by us are correct and we are fully responsible for the correctness of the information and documents submitted by us.

Yours faithfully,

(Signature of the authorized person of the firm/contractor with office seal)

SECTION-III

APPLICATION FORM

PART-1 (BASIC INFORMATION)

Annual Maintenance Contract for Operation & Maintenance of water supply, sewage system and carpentry works on 24x7 Basis on all days at TIFR, Survey No. 36/P, Gopanpally (Village), Serilingampally (Mandal), RR Dist., Hyderabad-500046.

1	Name of the Contractor / Firm / Organization / Company.	
2	Official Address for Correspondence with Telephone & Mobile Nos.	
3	Correspondence address at Hyderabad with contact person's name, telephone number, mobile number etc. (The company should have office and service facilities at Hyderabad)	
4	Type of Firm / Organization, whether proprietorship, partnership or private limited company etc.	
5	Year of establishment	
6	Name of the Proprietor / Partners /Directors in Organization	a) b) c) d)
7	A) Details of Registration (Firm ,Company etc)	To be filled by the vendors
	a) Registering Authority	
	b) Date	
	c) Number	
	B) Details of Labour license	

	ii. Reg No.	
	iii.Date of issue	
	iv.Date of expiry.	
	C) Details of Contractor's/Works license	
	i.Registering Authority	
	ii.Registration No.	
	iii.Date of issue.	
	iv.Date of expiry.	
	(Copies to be enclosed).	
8	Details of Income Tax Permanent	To be filled by the vendors
	a) Account Number (PAN No.)	
	b) Details of TIN No.	
	c) Details of EPF No.	
	d) Details of ESI No.	
	e) Details of GST No.	
	(enclose a copy of the certificate competent Authority)	
9	Annual turnover of the firm for the last three years ending March 31, 2023 should be at least Rs.16.17 lakhs. The annual turnover format is given below and should be signed and stamped by CA on the letterhead. (Furnish copies of Balance Sheet and Profit & Loss Account)	a)For F.Y. 2022-23: b)For F.Y. 2021-22: c)For F.Y. 2020-21:



10	Whether registered / empaneled with any of the Govt., Semi Govt., MES, IIT, NIT, IISc, Govt. Undertaking, Public Sectors etc. as approved Contractors and if so, furnish details.	
11	Whether any technical personnel are employed with the Firm / Organization and if so, give details of their experience, qualification	
12	If involved in any litigation earlier with any organization. If so, please submit the details.	
13	Any civil suits pending in any of the works executed. If so, furnish details.	
	Signature of the Contractor / Authorized person on behalf of the firm/organization	



PART-II

EXPERIENCE

Annual Maintenance Contract for Operation & Maintenance of water supply, sewage system and carpentry works on 24x7 Basis on all days at TIFR, Survey No. 36/P, Gopanpally (Village), Serilingampally (Mandal), RR Dist., Hyderabad-500046.

A) List of similar works / contracts executed by the contractor / Firm / Organization During the last 7 years prior to last month ending to the date of application issued.

Sr.No.	Name of the work	Name & Address of the Company for whom the work was executed	Nature / Type of the work	Name, Address & mobile/phone No. of Officer / Person under whom the work was carried out	Value of the work executed (Rs)	Duration of the Contract with commencement and completion date
1						
2						
3						
4						
5						

Note: Copies of the work orders and performance certificate should be enclosed



B) List of similar works / contracts being executed presently by the contractor / Firm / Organization

Sr.No.	Name of the work	Name & Address of the Company for whom the work was executed	Nature / Type of the work	Name, Address & mobile/phone No. of Officer / Person under whom the work was carried out	Estimated value of the work (Rs)	Duration of the Contract with commencement and expected date of completion
1						
2						
3						
4						
5						

Note: Copies of the work orders should be enclosed

Signature of the contractor / Authorized person on behalf of the Firm / Organization



C) Audited Annual Turnover for the last 3 years:

Sr. No.	Financial / accounting Year	Profit (Rs.)	Loss (Rs.)	Annual Turnover (in INR)
1.	2020-2021			
2.	2021-2022			
3.	2022-2023			

Note: The Audited Annual Turnover (Latest 3 Years) should be certified by Chartered Accountant (CA) as per the format given above duly signed and stamped by the CA on their letterhead.



SECTION-IV

ELIGIBILITY CRITERIA FOR TENDER QUALIFICATION

I. Eligibility criteria:

- 1 The contractor should have at least three years of experience in providing Operation & Maintenance of respective areas as mentioned in 'Scope of Work'.
- 2 The contractor should have carried out qualifying works stipulated in large premises of Research Institutions, Laboratories, Universities, IIT/IISc, Govt. Organizations, Institutions, multinational companies etc.
3. Annual average turnover of the contractor during the last 3 years ending March 31, 2023 should be at least Rs.23.50 Lakhs.
4. IT Returns for the last three consecutive financial years ended on March 31, 2023.
5. The tenderer should have satisfactorily carried out Annual Maintenance Contract for Operation & Maintenance of water supply, Sewage system and carpentry works on 24x7 Basis on all days works for Premier Research Institutes, Universities, Public Sector Undertakings(PSUs) institutes, Multinational Companies (MNCs) etc. for following contract value/s during last 7 (Seven) years as on previous month ending to the date of issue of application
 - i. One (1) similar work of AMC contract with minimum value of around Rs.37.60 lakh per annum
 - Or
 - ii. Two (2) similar works each of AMC contract with minimum value of around Rs.28.19lakh per annum
 - Or
 - iii. Three (3) similar works each of AMC contract with minimum value of around Rs.18.80lakh per annum.
6. The contractor should have an office in Hyderabad.
7. The contractor should have valid registration with all Statutory Authorities such as Registrar of firms, Central/State Labor Department (with valid license), ESI, PF, GST, PAN etc.
8. The contractor should submit a solvency certificate for not less than Rs.18.80 lakhs issued by any nationalized banks on or after 01.04.2023.

The contractor should submit documentary evidence in support of fulfilling eligibility criteria mentioned above.

Note:

- The details furnished shall be for the maintenance jobs & not for the installation works. The contractor must have experience in operation & maintenance of Sewage Treatment Plant (STP).**The vendors submitting the credential of installation works shall not be eligible for prequalification.**

- The track record of the contractor should be clean and he should not have any involvement in any illegal activities or frauds.

II. Credentials:

- The tenderer should also furnish the following information in Cover-1 (Prequalification Bid): Information desired regarding eligibility criteria as per given format in above
- Company profile & Bank's NEFT details of the company/contractor/firm etc.
- Name & address of the clients for whom the jobs were executed as per given format given in (Part-2).
- Copies of the Certificates from the clients for satisfactory performance

Desirous tenderers may either download the applications from our website

(<https://www.tifrh.res.in/index.php/commercial-tenders/> & **Tender reference no TIFR/PD/CF23-198/231608** or collect the tender document from TIFR-Hyderabad, HEAD-Technical Services at Survey No. 36/P, Gopanpally(Village), Serilingampally (Mandal), RR Dist, Hyderabad-500046 and submit completed applications along with the required documents.

III. Earnest Money Deposit:

Earnest Money Deposit (EMD) of Rs.93,980/- (Rupees Ninety three Thousand and Nine hundred Eighty only) shall be submitted in form of Demand Draft from Scheduled Bank drawn in favor of "TIFR Centre for Interdisciplinary Sciences", Hyderabad. The EMD so obtained shall be submitted in Cover-1 of the tender.

III. Instruction for Filling & Submission of Tender:

The tender amount is to be inserted in words as well as in figure in the space provided, in case of any discrepancies in the prices written in words and figures, the prices written in the words shall be considered to be correct.

The quoted rates should be with consideration of latest Minimum Wages payable as per Central Labour Wages Acts, 1948.

The tender shall be submitted in two cover systems. Cover-1 shall contain the letter inviting tender, instructions for tendering, tender conditions, the scope of work, EMD of Rs.93,980/- Cover-2 shall contain only the Bill of Quantities (Price Bid) i.e. the rate quoted for the contract. Each page of tender shall be signed by an authorized person of the firm and duly stamped. Both the covers shall be super scribed with the name of work.

Cover-1 & Cover-2 shall be put in a third sealed cover super scribing with "Annual Maintenance Contract for Operation & Maintenance of water supply, sewage system and carpentry works on 24x7 Basis on all days" at TIFR, Survey No. 36/P, Gopanpally (Village), Serilingampally (Mandal), RR Dist., Hyderabad-500046. on or before 13:00 Hrs on 28.02.2024.

"Price BID": Signed copy of the Price Bid quoting amount in the stipulated format.

Tender fee or Earnest Money Deposit (EMD): EMD shall be submitted in the form of Demand Draft to be drawn in favor of "TIFR Centre for Interdisciplinary Sciences", Payable at Hyderabad (To be enclosed with the Technical Bid Part-I))

SECTION-V	SCOPE OF WORK
------------------	----------------------

The contractor shall attend to all the works as per scope of the work mentioned under each head of works i.e., operation & maintenance of STP Plant, Plumbing installations, Carpentry works given below:

I. Operation & Maintenance of Sewage Treatment Plant (STP):

The process flow diagram (PFD) of STP and details of the pumps and tanks are as under

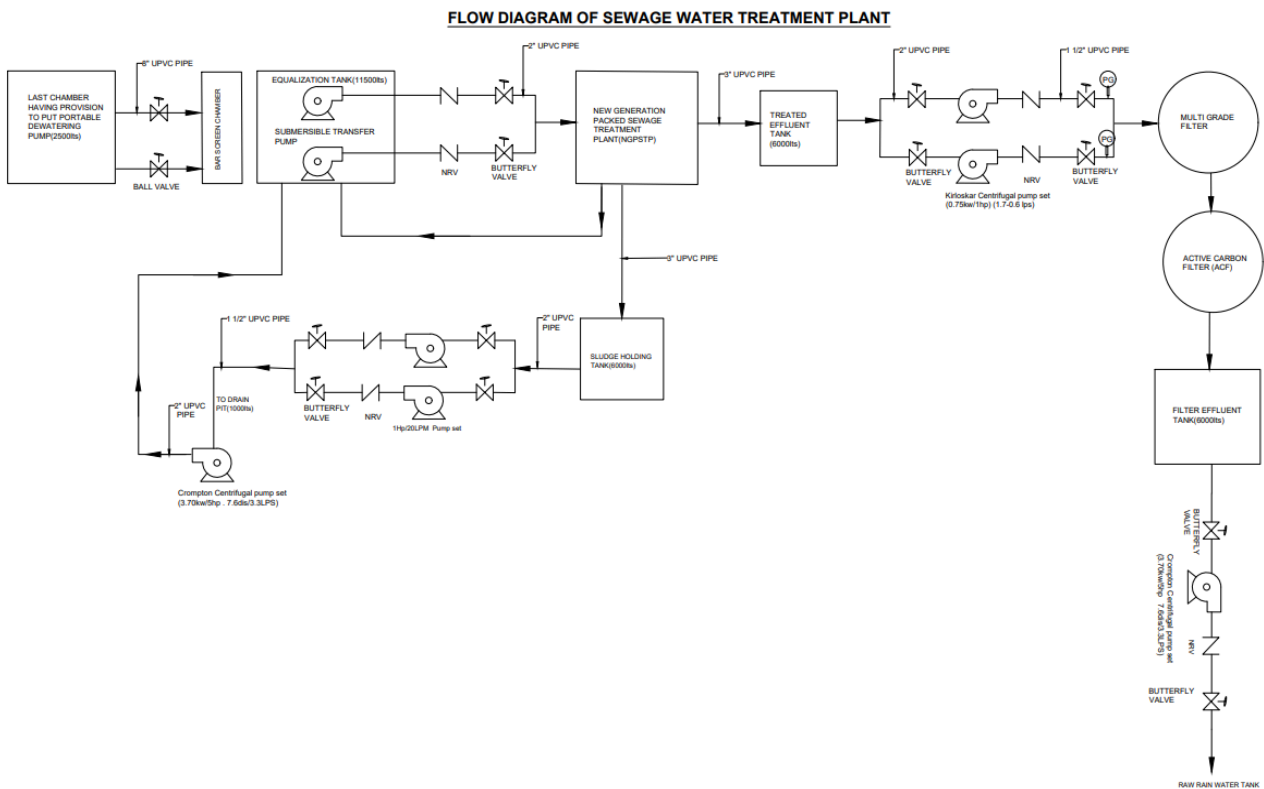

Details of pumps & storage tanks

Sr. No.	Description	Capacity	Location
1	Collection Tank	2500 liters	Service Building -2
2	Equalization Tank	11500 liters	Service Building-2
3	NGPSTP	30 KLD	Service Building-2

4	Treated Effluent Tank	6000 liters	Service Building-2
5	Multi grade filter.	600 Ø	Service Building-2
6	Activated Carbon	600 Ø	Service Building-2
7	Filter Effluent Tank	6000 liters	Service Building-2
8	Sludge Holding Tank	6000 litres	Service Building-2

A) Scope of work for STP

Daily checks:

- Operation, Monitoring of complete STP plants and maintaining log sheet.
- Checking the level of sewage collected in the Equalization Tank.
- Sewage transfer pump operation.
- Maintain the constant flow from the equalization tank to NGPSTP.
- Checking the level of the STP tank.
- Greasing and oil should be checked regularly.
- Media cleaning to be done as and when required by the contractor.
- Make sure that the blower should run round the clock.
- Prepare the hypo chlorine solution of required ppm.
- Daily check the level of chlorine storage tank.
- Setting up of dosing ppm as per the outlet quality.
- Main the daily consumption of Sodium hypochlorite (Payments to be made as per actual consumption) in a log book.
- Checking the level of Filter feed tank.
- Manual checking of suspended solid.
- If the suspended solids are present in the filter feed tank, check for proper settlement in the secondary settling tank.
- Maintenance and checking of Filter feed water pumps.
- Normal operation of multi grained filter (MGF) & activated carbon filter (ACF) as per the instruction given in the manual.
- Backwash of MGF & ACF based on differential pressure.
- Prolonged backwash of MGF & ACF as and when required.
- Rinsing of MGF and ACF filters when required.
- Monitoring the quality and recording in the logbook and status report.
- Effluent analysis would be carried out by a contractor, once in a month.
- Technical audit would be carried out by the technical services team of the contractor once in 6 Months.

- Monthly once an Engineer visits STP for monthly monitoring of the treatment process.
- Training will be provided to the operator by the contractor, if required.
- The detailed schedule of operation, routine, special and preventive maintenance along with daily, fortnightly, monthly activities for all the works and execute as per the direction of Engineer in Charge. However tentative minimum routine and preventive schedule shall be as under:

Monthly checks:

- Greasing and oil should be checked regularly.
- Make sure that blower should run round the clock.
- Prepare the hypo chlorine solution of required ppm.
- Maintenance and checking of Filter feed water pump.
- Effluent analysis would be carried out.

B) Maintenance & Cleaning:

Besides the above routine works, the scope of work shall include removing of sludge from STP, cleaning the all equipment which belongs to STP, arresting leakages in the water supply and sanitary lines by using zinc and spun yarn/cement, removal of chokes from STP inlet & outlet lines

C) Replacement of Spares:

- i. Cost of individual spares required for replacement/maintenance of STP items, shall be borne by TIFR-Hyderabad.
- ii. The necessary vouchers /invoices are required to be submitted for items payable by TIFR-Hyderabad for settlement of their bills along with the DC duly and work completion certificate duly certified by the TIFR Officials/Engineer. In such case, TIFR-Hyderabad shall pay cost of materials on actual plus 15% towards overhead and profit and no extra payment towards labor will be made.
- iii. For all the works mentioned in (i), the contractor is advised to submit the comprehensive bill including DC and work completion certified by the TIFR Officials/Engineer along with the monthly bill.
- v. Operator should have proper uniform with continuous display of Identity Card. Operator should be provided with a tool bag containing all the necessary tools.

D) The following Plumbing tools and machinery in two sets shall be provided by the Contractor along with a tool box / tool bag.

1. Cutting Player
2. Monkey Player
3. Screw Drivers
4. Spanners
5. Hammer
6. Adjustable Wrench

7. Pipe Wrenches
8. Hacksaw
9. Pipe Cutter
10. Measurement Tape
11. Plunger

- E) Arrange visit of STP engineer (must be holder of Environmental B-Tech or M-Tech should be able to certify the water quality test report) once in a Month for inspection and submit report to TIFR-Hyderabad's Engineer about his observations. He should also visit whenever major repairs of STP in the premises of TIFR-Hyderabad. Details regarding Skilled Operator i.e. Name, Qualification, Experience shall be given at the time of submission of tender.**
- F) The contractor is required to maintain following registers during the job of AMC:**
- i) Daily inlet & outlet water register
 - ii) Daily plant running time register
 - iii) Daily Backwashing register
 - iv) Checklist as per scope of work
 - v) Shift report register
 - vi) Daily consumable register and payment to be made on actuals.
- G) Contractor shall follow the prescribed formats/procedures for receiving complaints, receiving the work slips duly sanctioned and preparation of bills etc. as stipulated by TIFR-Hyderabad from time to time.**
- H) Contractor shall maintain a proper record/register indicating reasons for not attending to any particular complaint within time schedule, failing which penalty shall be levied.**
- I) The Contractor shall attend to all the works 24X7 basis and post One Skilled plant operator (Should be of ITI background with 3 years experience) in general Shifts (ie. from 9:00 am to 5:30 pm) on all days; on weekly six days during the entire contract period for operation & Maintenance of the above said works. The contractor shall provide minimum one-day duty off once in a week for the employees working in shifts and shall provide relievers for the employees on off duty / sick / leave. However, in case of exigencies, the contractor shall provide services beyond the above mentioned hours.**

II. Operation & Maintenance of Water supply & Sewerage installations:

The following are details of the pumps and tanks maintained as under.

Pumps & Filters

Sr.No.	Description	Capacity	Location
1	Domestic water pumps- 2 Nos	100 LPM @ 45m head	Dry well – Service Building -1
2	Rain Water Harvesting System	72000 Ltr/ Hr	Basement- Service Building-2
a	Feeding pumps- 3 Nos	1200 LPM@ 15m head	Basement- Service Building-2
b	Dosing pumps for chlorination & alum- 3 Nos.	10 Ltr/ hr (Rating)	Basement- Service Building-2
c	Sand Separators (Hydro cyclone filter)- 3 Nos.	120 Cum/Hr.(Filter rate) Working Pressure-5 Kg / Sqcm	Basement- Service Building-2
d	Pressure filters- 3 Nos	125 Cum/Hr (Filter rate) Working Pressure-2.5Kg / Sq Cm	Basement- Service Building-2
e	Chemical Storage Tanks-2 Nos for dosing usage (Sodium Hypochlorite)	100 Ltr each for STP and Rain water harvesting plant	Basement- Service Building-2
f	Rain water(filtered) flushing pumps- 2 Nos	35 LPM	Basement- Service Building-2
3	Bore well submersible pumps- 3 Nos.	50 LPM@130m head	Each at NE Corner of Campus, Behind Service Building-1 and Behind Service Building-2



4	RO water pumps -3 nos	200 LPH RO Unit, Feeder pump - 1 no, Booster pump- 1 no Filter pump -1no	RO water pump room at terrace of main building, Right side.
5	RO water pumps -6 nos	200 LPH RO Unit, Booster pump- 5 no Filter pump -1no	RO water plant at Hangar-2 in Plot-B.

Water Tanks:

Sr. No.	Description	Capacity	Location
1	OHT (Domestic) – 2 Nos x10000 Ltr	20000 Ltr	Main Building
2	OHT(Fire Fighting) – 2 Nos x 20000 Ltr	40000 Ltr	Main Building
3	OHT(Flush water) – 2 Nos x 5000 Ltr	10000 Ltr	Main Building
4	OHT(Gardening) – 2 Nos x 20000 Ltr	40000 Ltr	Main Building
5	OHT (Domestic) – 1 Nos x10000 Ltr	10000 Ltr	Service Building-1
6	OHT(Fire Fighting) – 1 Nos x 10000 Ltr	10000 Ltr	Service Building-1
7	OHT(Flush water) – 1 Nos x 5000 Ltr	5000 Ltr	Service Building-1
8	OHT (Domestic) – 1 Nos x 5000 Ltr	5000 Ltr	Service Building-2
9	OHT(Fire Fighting) – 1 Nos x 20000 Ltr	20000 Ltr	Service Building-2
10	OHT(Flush water) – 1 Nos x 2000 Ltr	2000 Ltr	Service Building-2
11	UG Tank (Domestic) – 1 Nos x 100000 Ltr	100000 Ltr	Service Building-1
12	UG Tank (Fire Fighting) – 2 Nos x 200000 Ltr	400000 Ltr	Service Building-1
13	UG Tank (Rainwater collection tank) – 1 Nos	350000 Ltr	Service Building-2
14	UG Tank (Filtered Rain water tank) – 2 Nos	1475000 Ltr	Service Building-2

15	Water Meter Chamber(HMWSSB) -1Nos	73000 Ltr/hr	NE Corner of Campus,
16	RO Water storage tanks – 2 Nos	500 Ltr each	Terrace of main building, Right wing.
17	RO Water storage tanks – 1 Nos	2000 Liters each 1000 Litres each	At Hangar 2 Building

A) Scope of the work:

The detailed schedule of operation, routine, special and preventive maintenance along with daily, fortnightly, monthly activities for all the works and execute as per the direction of Engineer In Charge. However, the tentative minimum routine and preventive schedule shall be as under.

Daily Checks:

- Monitoring of water supply from HMWS & SB lines, checking of water storage in UG sumps with supply from HMWS & SB. Maintaining records such as water meter reading, water storage levels in sumps etc.
- Pumping of domestic water to all terrace tanks. Maintaining records of water pumping.
- Pumping of flush water from filtered water storage tank to all terrace tanks. Maintaining records of water pumping.
- Pumping of water from filtered water storage tank to all terrace gardening water tanks. Maintaining records of water pumping.
- Pumping of domestic water to 200 lph RO water plant at terrace. Maintaining water level records.
- Checking of all water lines (internal & external) relating to HMW & SB, domestic, flushing, gardening, bore water, firefighting and RO water lines against leakage.
- Checking of water supply fittings, fixtures in labs and toilets.
- Checking of drain pipe lines in labs and toilets against choking.
- Checking of sewer lines to ensure proper flow in pipes.
- Visual Checking of electrical panel relating to pumps of domestic, flushing, bore well, RO water supply.
- Maintain check sheets, various registers etc properly.
- Submission of daily shift reports to E.I.C.
- Constantly coordinate with AMC Vendors of RO Water Plant & NGPSTP in case of any breakdown/problem/monthly checks etc. and get the service done by them.

Weekly checks:

Functioning and service checking of all pumps and accessories relating to domestic, flushing, gardening, rain water harvesting, firefighting, RO water systems.

- Checking of Gully traps, manholes relating to sewer lines against choking.

Monthly checks:

- Proactive plumbing preventive maintenance i.e. checking of active leaks, water pressure, sign of corrosion, checking of valves for correct operation, checking drains against clogging etc.
- Checking of all firefighting water pipe lines, fire hydrants, fire hoses, fire hose box, Hose reels, pressure gauge and pressure switch.
- Replacing of gasket & Washer (if leakage/faulty are noticed)

Quarterly checks:

- Cleaning of terrace water tanks.
- Cleaning of underground sumps of domestic and firefighting.
- Cleaning of filtered rain water underground storage tanks.
- Cleaning of rainwater spouts free from dead leaves and dust accumulation.
- Cleaning of R.O. water storage tanks.

Half yearly checks

- Cleaning of storm water drains to ensure free flow of water in drains during monsoon.
- Cleaning of rain water collection tank.

B) Maintenance & Cleaning:

Besides the above routine works, the scope of work shall include arresting leakages in the water supply and sanitary lines by using zinc and spun yarn/cement, removal of chokes from water closets, urinals, wash basins, sinks, floor traps, soil and waste pipes, rain water pipes, porcelain traps and underground drain lines and water lines inside the compound. Also making holes in stone/brick masonry and RCC walls of any size, roofs, chajjas etc. to facilitate plumbing works etc. and providing scaffolding wherever required.

Carrying out cleaning of all the water tanks indicated in iii. B above the building once in 3 (three) months (i.e. four cleaning per year). Cleaning should be carried out with a water pressure type machine, disinfecting materials such as bleaching powder, potassium permanganate. Cost of above materials is included in the scope of work and no extra payment shall be made in this regard.

- i. All terraces in the buildings, which are provided with rainwater outlets are required to be cleaned for any dead leaves, silt etc. once in 15 days or as & when required. The debris collected shall be disposed off in the municipal garbage site provided near the building.
- ii. All Trap provided near the canteen and lounge shall be cleaned once a week by opening the manhole covers and removing the obstacles, if any, from the chambers. The lines shall be flushed and kept free of any trapped oil etc.
- iii. Besides maintenance and operation of water pumps, sump pumps and rain water harvesting system pumps, control panel for sump pumps, RO Water pumps the scope of work shall also include regular servicing/maintenance pumps & installations like oiling,

greasing, replacement of gasket packing etc. twice a month & in case of emergency breakdown, by a specialized agency in basement & on any floors, work may be carried out as directed by TIFR-Hyderabad.

- iv. Periodical checking and cleaning of drain pipes, rainwater pipes and storm water drains and rain water gutters at hostels before and during monsoon to ensure proper flow and avoid choking in pipes/drains. **The contractor shall provide man lifter machinery for cleaning of all gutters at hostels, the hire charges for providing man lifters shall be borne by the contractor**

C) Replacement of Spares:

Cost of individual spares such as bottle trap, flush valve, seat cover, bib tap etc. required for replacement/maintenance of the plumbing/sanitary items, shall be borne by TIFR-Hyderabad.

The necessary vouchers /invoices are required to be submitted for items payable by TIFR, Hyderabad for settlement of their bills along with the DC duly and work completion certificate duly certified by the TIFR Officials/Engineer. In such case, TIFR-Hyderabad shall pay cost of materials on actual plus 15% towards overhead and profit and no extra payment towards labor will be made.

The contractor is advised to submit the comprehensive bill including DC and work completion certified by the TIFR Officials/Engineer along with the monthly bill.

D) The following Plumbing tools and machinery shall be provided by the contractor along with tool box/ tool bag for Plot-C and Plot-B Campuses

1. Cutting Player
2. Monkey Player (Rib-joint pliers)
3. Screw Drivers
4. Spanners Set
5. Drilling Machine
6. L-Angle Set
7. Hammer
8. Adjustable Wrench
9. Pipe Wrenches
10. Hacksaw
11. Pipe Cutter
12. Measurement Tape
13. Plunger
14. Angle Grinder
15. Cordless Combo Drill
16. Chipping machine
17. PPR welding machine (sizes 1/2" to 4 inches)

- E). Arrange visits of Plumbing Engineer once in a quarter for inspection and submit a report to TIFR-Hyderabad's Engineer about his observations. He should also visit whenever major repairs of existing pipelines in the premises of TIFR-Hyderabad. Details**

regarding Skilled Operator i.e. Name, Qualification, Experience shall be given at the time of submission of tender.

- F).** The contractor is required to maintain following registers during the job of AMC:
- i) Daily pump operation register
 - ii) Daily water tank filling register
 - iii) Daily checking of toilets attending the faults/complaints
 - iv) Check list as per scope of work
 - v) Shift report register
- G).** Contractor shall follow the prescribed formats/procedures for receiving complaints, receiving the work slips duly sanctioned and preparation of bills etc. as stipulated by TIFR-Hyderabad from time to time.
- H).** Contractor shall maintain a proper record/register indicating reasons for not attending to any particular complaint within time schedule, failing which penalty shall be levied.
- I).** Operation & Maintenance of Water Supply, Sewerage, Sanitation, Plumbing including servicing of Sanitary fittings & fixtures, Rain water harvesting system, RO Water Plant and Fire Fighting Installations on 24x7 basis and post 3 skilled workers/plumbers (Should be of ITI background with 3 years experience) in 3 shifts (i.e. from 6:00 am to 2:00 pm, 2:00 pm to 10:00 pm and 10.00am to 06.00am) on all days during the entire contract period and one skilled person in General shift (i.e. 9:00 am to 5.30pm) with one reliever .The contractor shall provide services beyond the above mentioned hours

III) Maintenance of Carpentry installations and fixtures:

Providing the services of a skilled carpenter (should be of ITI background with 3years experience) on general shift (i.e. from 09:00 am to 5.30 pm) on weekly six days during and post one unskilled helper on general shift.

A) Scope of carpentry works:

- Attending to all the complaints mentioned in complaint Register/received in writing relating to carpentry and allied works and rectifying the defects wherever necessary including cost of minor materials (with necessary tools and minor items like adhesives, screws, nails, nut & bolt, washer, brackets, clips etc. as well as items/works costing individually will borne by TIFR Hyderabad) replaced in the premises
- Repairing of Wooden door, Wooden cabinets, Wooden Table, shelves, cupboards, pelmets and other wooden members, chairs etc. attending to necessary repairs and adjustments for easy operation of shutters using necessary commodities similar to the existing one for filling up the holes, if any, in the frames. Replacement of wood, veneer, laminates, door closer and glass will be paid extra.

- Repairing of aluminum windows, doors, ventilators, partitions cutting and removing the damaged sections, replacing with suitable aluminum sections for frames, stiles and rails, gaskets, attending to necessary repairs and adjustments for easy operation of shutters using necessary commodities similar to the existing one for filling up the holds, if any, in the walls. Replacement of aluminum section, laminated particle boards, door closer and glass will be paid extra.
 - Repairing of MS doors, gate rolling shutters, MS .grills by cutting and removing the damaged portions, replacing with suitable MS sections for frames, shutters, attending to necessary repairs and adjustments for easy operation of shutters using necessary commodities similar to the existing one for filling up the holes, if any, in the frames. Replacement of MS sections, members and glass will be paid extra as well as for arrangement of welding machines & welders
 - Making holes in stone/brick masonry and RCC wall of any size, roofs, chajjas, etc. to facilitate Civil, plumbing and carpentry works and making goods the same wherever necessary.
 - Rectifying and replacing hooks, hinges, aldrops, tower bolts, knobs, handles, door locks, door closers, door stoppers, floor springs, hold fasts, bearing, clamps, picture hooks, nails, screws, nylon rope and brackets for cloth drying arrangement etc. , with suitable material like the existing one Leveling of doors and window surfaces to ensure proper functioning of doors, windows ventilators etc.
 - Fixing and replacement of glass panes to windows ventilators of different sizes at all places including fixing of putty to existing glass panes of windows.
 - Repairing of workstation, installing necessary fixtures wherever needed.
 - Any other work not covered above but related to carpentry.
 - Providing the services of a skilled carpenter (should be of ITI background with 3years experience) on general shift (i.e. from 09:00 am to 5.30 pm) on weekly six days during and post one unskilled helper on general shift.
- B) The following carpentry tools and machinery shall be provided by the contractor along with tool box/ tool bag for Plot-C and Plot-B Campuses**
- Hand saw
 - Spirit level
 - Claw hammer
 - Wood carving hand chisel 38mm.
 - Nail gun
 - Drill machine 10mm battery operated & power operated
 - Quick clamp
-

- Block plane
- Trimming or utility knife
- Circular saw
- Screw drivers
- Clamp
- Carpenter square
- Work bench
- Measurement tape
- Cutting Machine 15" size (for cutting of aluminum profile sections)
- Hammer machine 22mm,
- Wall cutter angle grinder 100mm
- Wood/ Tile cutter 110mm
- Screwdriver 15" & 18" size
- Nail puller
- Carpenter plane (Randa) 6" size.
- Tri square

* * * * *

General

The contractor shall attend to all the works 24X7 basis as per scope of the work mentioned under each head of works i.e., operation & maintenance of STP Plant, Plumbing installations, Carpentry works etc.by posting required staff.

The contractor shall provide minimum one-day duty off once in a week for the employees working in shifts and shall provide relievers for the employees on off duty / sick / leave. However, in case of exigencies, the contractor shall provide services beyond the above mentioned hours. The TIFR- Hyderabad shall not permit double shift for any staff employed by the contractor.

Contractor should provide uniforms, shoes, safety & protection gear, identity Cards, working tools etc. to the staff deployed, at no extra cost.

Log book and complaint books, all stationery like registers, sheets, markers, pens and pencils etc. will be supplied by the contractor and no extra payment for these shall be made. Log book format must be approved by TIFR Engineer- in- charge.

No work shall be partially or fully stopped for want of personnel or tools or instruments. If such an event occurs, the fine will be levied.

Contractor will ensure consistency of work and work force, correct troubleshooting, good workmanship, follow all safety procedures and will make all necessary efforts to maintain a healthy environment and reliable services.

If any of the staff members appointed by Contractor is found to be 'not competent', he has to be replaced by a right person within a stipulated time as given by Engineer In charge, TIFR-Hyderabad.



All the relevant documents pertaining to staff deployed, like copies of job appointment order with the contractor, address proof, photocopy of ID card etc. and any other details as sought shall be provided to TIFR-Hyderabad, by the contractor under his responsibility for the correctness.

Wages of the staff deployed should not be less than as that mentioned in Minimum Wage Act applicable to the respective category/experience, as on date. The ESI, PF, gratuity, bonus etc., labor law, and other rules & norms requirements as found required for contracts of this nature should be met. The same details shall be submitted along with a tender bid.

In no case, the contractor or his/her employees shall claim job / employment with TIFR-Hyderabad. No transport facility shall be provided for the contractors employees by TIFR-Hyderabad.

In case of delay, repetition of work, noncompliance, and inadequate staff etc. fine will be imposed as per the fine clause mentioned.

Safety aspects in work places have to be followed as per relevant standards & codes. Any accident or damage to death will be treated as negligence & it is purely the responsibility of the contractor. TIFR- Hyderabad is not responsible for any accidents or damages to death. Safety of all the staff under this contract is the sole responsibility of the contractor.

Contractor is responsible for the behavior & conduct of his workmen and hence they should be properly educated and controlled.

All the removed materials for routine maintenance works should be brought to the office for accountability and a separate register needs to be maintained showing all received/used plumbing, carpentry and other material supplied by the TIFR- Hyderabad. No materials should be left anywhere on the campus.

All tools and machinery required for routine works, preventive maintenance etc., shall be provided by the contractor.

All breakdown calls/complaints received during normal working hours should be attended to as early as possible. No complaints should be left unattended and not be postponed to the next day.

Any damage caused to any equipment or items available at the office premises due to negligence of the contractor's work force shall be entirely on the contractor, the amount so involved on this account shall be deducted from the payment due to the contractor.

Documents to be maintained by the contractor:-

1. log book of daily events
2. Complaints registers
3. Planning and scheduling of preventive maintenance
4. Reports of preventive maintenance done
5. Daily breakdown maintenance/status reports
6. Reports of testing/checking done
7. Reports of modification done

- 8. Attendance sheet.
- 9. Details of plant record book

FINE CLAUSE:

Operation & maintenance of plumbing, carpentry and STP operation on a 24x7 basis is very essential and critical. Non-availability may result in many tangible & intangible losses in research work, equipment, animals, tissues etc.

Hence all the work routine, servicing, breakdown maintenance has to be carried out in accordance with all standards and statutory norms with minimum time and maximum accuracy to ensure maximum availability. Failure in meeting the above requirements will attract the 'fine' clause as below.

Contractor should depute experienced personnel to carry out maintenance work both low & high side in such a way that the repetition of the problem should be avoided.

If the contractor fails to comply with the tender conditions, penalty would be levied on the following basis:

S.No.	Works Not Performed	Penalty
1	Not providing adequate staff as per tender.	Salary for the worker for the day of absence will be deducted from the bill. plus Rs.500/- per day for not providing the labor.
2	Non- payment of minimum wages & any other statutory wages to the workers as per the Central minimum wages act, PF, Insurance act, bonus act etc.	The bill amount will not be paid to the Contractor however the wages will be paid to the workers directly as per their attendance for the month. If not rectified, the contract will be terminated with prior notice.
3	Not performing any activity under "Day to day maintenance"	Rs.5000/- per month for three consecutive times and after that, the contract will be terminated.
	Penalty will be imposed as per TIFR's discretion, in the case of claiming exorbitant amount for the materials/any other works by the contractor, failing/non-operation of pumps by the plumbers and any other discrepancies found in the contract services other than the above.	

TIFR-Hyderabad / concerned engineers will be authorized to deduct the amount from the contractor bill or security deposit or initiate any other action as found suitable.

Contractor must visit the site, understand the site condition, type of work involved, quantum of work etc., for carrying out works, before quoting.



INSTRUCTIONS FOR TENDERERS

1. Before filling up the tender, the tenderers are requested to visit the site and also carefully examine the tender documents, conditions of contract, specifications, scope of work etc. The tenderer shall ascertain the location, size and condition of the areas available for his use as working areas and all other information affecting his tender.
2. Service is the essence of the contract and the systems (water supply and plumbing and sanitary/drainage system and Rainwater harvesting systems must be maintained efficiently as indicated in the Appendix to Form of Tender. Any tenderer, which disagrees with terms & conditions of the tender, is liable to be rejected.
3. The tender form and the documents attached to it shall not be detached one from the other and no alteration or mutilation (other than filling in all blank spaces) shall be made in any of the documents attached hereto.
 - i) The tenderer shall completely fill the required Annexure and Price Bid. The tender shall be signed by person or persons so authorized by the tenderer with signature duly witnessed. The tenderer shall sign each of the document pages and duly stamped.
 - ii) The tender shall contain postal address, e-mail ID, Tel. no. and Fax. No. for correspondence/servicing instructions, required to be served to the tenderer in connection with tender/contract.
4. The tender shall accompany the following information & schedules:
 - i) Details of past/present experiences in performing works/contracts of similar nature and magnitude.
 - ii) True copy of PAN, GST registration.
5. TIFR-Hyderabad will not be responsible and will not pay any expenses which may have been incurred, or losses to person or property suffered by the tenderer in connection with visits and examination of the site and in the preparation of the tender for submission.
6. The vendor (whether or not he submits the tender) shall treat the details of the document as secret and confidential.
7. TIFR-Hyderabad reserves the right to adjust arithmetical or other errors in any tender in the way, which he considers suitable. Any adjustments so made by TIFR-Hyderabad shall be stated to the tenderer if TIFR-Hyderabad makes an offer to accept his tender.
8. The service charges would be payable on the completion of one month service and on submission of the bills. In case of unsatisfactory performance, TIFR-Hyderabad may terminate the contract by giving 1 (One) month notice. However, the contractor shall give 3 (three) months' notice to TIFR-Hyderabad in case he decides to terminate the contract.
9. TIFR-Hyderabad is not bound to accept the lowest or any tender and has the right to refuse any tender without assigning any reason. TIFR-Hyderabad also has right to re-issue the tender without tenderers having the right to object to such re-issue



SECTION-VI

GENERAL TERMS & CONDITIONS

1. The AMC shall be initially for a period of one year and shall be extendable up to two more years on observation of satisfactory performance on mutually agreeable financial terms.
2. The contractor shall provide the maintenance services as given in 'Scope of Work' to the satisfaction of the TIFR-Hyderabad. The performance of the contractor shall be reviewed on a monthly basis and in case the services are not found to be satisfactory, the contract shall be terminated even before the expiry of contract period by giving one month's notice. However, the contract is liable for immediate termination on violation of any provisions by the contractor. The TIFR- Hyderabad may also terminate the contract in the instance of insolvency or bankruptcy of the contractor or change of ownership of the business of the contractor. The TIFR- Hyderabad shall not pay any compensation for early termination. The security deposit/Performance bank guarantee submitted under the contract shall be liable to be forfeited and shall be absolutely at the disposal of TIFR, Hyderabad.
3. If the contractor fails to execute the maintenance works as detailed in 'Scope of Work' within stipulated time, the TIFR- Hyderabad will be at liberty to execute the works through an alternate source and the charges incurred shall be recovered from the contractor.
4. The contractor shall permit the TIFR- Hyderabad to hold or deduct the amount from the bill for non-performance or part performance or failure to discharge obligations under this contract.
5. The contractor, whose tender is accepted, shall deposit an amount equal to **5 % of the contract value towards Security Deposit** for the due performance of the contract, which shall be refundable after expiry/termination of the contract. The deposit shall not bear any interest.
6. The contractor shall obtain at his own cost, any license or permission of any sort whatsoever (viz., labor license from Assistant Labor Commissioner (Central), Hyderabad and register with Employees' State Insurance Corporation and Office of the Regional Provident Fund Commissioner, Hyderabad, GST, Income Tax etc.) that may be required under various Acts from the Central/State Government Authorities for carrying out the said activity in the premises of the TIFR-Hyderabad and such Registrations and License for engagement of contract workers for such purpose within one month from the date of issue of work order.
7. The contractor shall comply with the provisions of all Labor Laws, which are applicable to 'the Contractor' or his employees and shall be solely responsible for liabilities arising out of such compliance, non-compliance or implementation or non-implementation. The contractor will furnish proof of compliance of all Labor Laws requirements including obtaining licenses, filing of monthly/quarterly/annual returns and any other statutory requirement and furnish calculations and proof of payments made to all Government/Statutory Authorities under EPF, ESIC, Labor Welfare Fund Act, Payment of

- Bonus Act, etc. within time limit allowed under the respective Acts and all other statutory rules as amended from time to time.
8. The contractor shall indemnify the TIFR- Hyderabad from all liabilities arising out of any payment/ in respect of any claims made by the contractor's employees against the TIFR-Hyderabad under any statute/notification of the Government (Central/State) or Statutory authority in respect of his employees.
 9. The contractor shall be responsible for maintenance of proper records as required under the provisions of various Labor Laws / Statutory Acts applicable to the contractor and contract employees such as attendance register, overtime register, advance register, register of deductions for damage & loss, register of fines, accident register etc. and produce them for inspection as and when demanded by TIFR- Hyderabad or any appropriate Labor authorities. The contractor shall also issue Form-XIV (employment card) to their personnel.
 10. The contractor shall make the payment to personnel engaged by him as per minimum wages notified by the Office of the Regional Labour Commissioner (Central), Hyderabad from time to time. The contractor shall satisfy the TIFR- Hyderabad showing adequate recorded proof that the minimum wages, ESI, contribution to provident fund as applicable are being paid to his personnel as required under various Statutory Acts notified by the Government from time to time. The contractor shall disburse wages payable to his personnel only in the presence of an authorized officer of the TIFR-Hyderabad.
 11. The contractor shall provide weekly off / holidays to his personnel as per applicable laws/ labor laws but it will be his responsibility to ensure uninterrupted services on all days.
 12. The contractor shall ensure that the character and antecedents of the personnel engaged by him are duly verified before such engagement.
 13. The contractor shall submit the list of his personnel to be deployed at the TIFR-Hyderabad along with their personal details like name, age, date of birth, permanent address etc. for approval. The TIFR- Hyderabad has the right to advise the contractor to replace any of the personnel engaged by him who are found unsuitable; the contractor shall immediately replace such personnel. The contractor shall provide identity cards to his personnel.
 14. The contractor shall not employ any person who is prohibited by law from being employed. The personnel deployed by the contractor should not suffer from any infectious disease and should be able-bodied persons.
 15. The contractor shall ensure that none of his personnel report for duty in a drunken state or consume drugs, prohibited substances, smoke, etc., while on duty.
 16. The contractor shall take necessary safety measures and he/she is solely responsible for the safety of personnel engaged by him. **The contractor shall provide appropriate uniform, shoes, gloves, accessories & tools that would ensure safety against**

insects & snakes, dogs and electrocution to all personnel and ensure their cleanliness and upkeep.

17. The TIFR- Hyderabad shall not be responsible for any accident/injury or loss of life of any of the persons engaged by the contractor that may take place while executing the contract. Any compensation or expenditure towards the treatment of such injury or loss of life shall be sole responsibility of the contractor. At his cost, the contractor shall obtain appropriate/adequate insurance policy to his personnel towards meeting the liability of compensation arising out of death, injury, disablement, etc. at work.
18. The contractor shall abide by all the rules and regulations laid down by the TIFR-Hyderabad authorities from time to time.
19. The contractor or his personnel shall not any time do, cause or permit any nuisance at the site / do anything which shall cause unnecessary disturbances or inconvenience to the occupants/visitors at site or near the site of work.
20. The contractor shall be responsible for all acts done by the personnel engaged by him and for maintenance of proper discipline by his personnel at the premises of the TIFR-Hyderabad. Any act of indiscipline/misconduct/theft/pilferage on the part of any personnel engaged by the contractor resulting any loss to the TIFR- Hyderabad in kind or cash will be viewed seriously and the TIFR- Hyderabad shall have the right to levy damages or fine from the contractor and even terminate the contract forthwith.
21. Care must be taken to ensure while carrying out the work so that no laboratory equipment, fittings, fixtures, furnishings are damaged. Any damages done to the same or any other property will have to be repaired / replaced by the contractor, failing which the TIFR- Hyderabad will get them repaired/replaced at risk and cost of the contractor.
22. In the event, any damage is caused to the movable or immovable property of the TIFR-Hyderabad or to the property of employees of the TIFR- Hyderabad, the TIFR-Hyderabad reserves the right to compute the damage in terms of money and to deduct the money from the bill of the contractor or from the amount payable to the contractor by the TIFR- Hyderabad and the remaining amount, if any, by the way of civil damages.
23. The contract is for providing maintenance services and the workers employed by the contractor for providing the services shall be of his/their employees and not of the TIFR-Hyderabad.
24. The personnel engaged by the contractor shall not have any employee-employer or master-servant relationship with the TIFR- Hyderabad and they shall not have any claim whatsoever for employment in the TIFR- Hyderabad now or at a future date.
25. The contractor shall remove his personnel peacefully on expiry of contract or on termination of the contract.

-
26. The contractor shall not subcontract the works unless permitted specifically by the TIFR- Hyderabad in writing.
 27. The contractor shall submit the bills in the first week of every month along with a monthly report for the works carried out in the previous month. The TIFR- Hyderabad shall pay AMC charges on monthly basis upon submission of bills by the contractor and certified by the concerned employee/official to the effect that the maintenance works have been carried out as per the contract. Applicable TDS will be deducted while making the payment. The GST, if any, shall be reimbursed by the TIFR- Hyderabad on submission of proof of payment along with the monthly bill.
 28. The contractor should provide mobile telephone on site for communicating 24 x 7 basis duty personnel.
 29. The contractor shall execute the agreement related to this contract on stamp paper as per proforma prescribed by the TIFR- Hyderabad.
 30. The contractor shall pay the minimum monthly wages (Central) fixed by the Chief Labour Commissioner (Central), Delhi, Govt. of India, Ministry of Labour & Employment under The Minimum Wages Act as applicable in Hyderabad.
 31. Enhancement in Administrative/Service charges, on any ground will not be entertained during the tenure of the contract for this intended period.
 32. The contract can be terminated on any of the following contingencies:
 - On expiry of the contract period.
 - By giving one month advance notice by TIFR on account of:
Un Satisfactory performance of the contract (as per tender terms and conditions).
 33. Losses suffered by TIFR due to lapse on the part of the contractor/his Supervisor/ workers.
 - i) For committing breach by the contractor of any of the terms and conditions of Contract.
 - ii) On assigning the contractor or any part thereof or any benefit or interest therein or there under by the contractor to any third person for sub-contracting whole or part of the contract.
 - iii) On violation of any Labour laws as per Contract Labour (Regulation & Abolition) Act, 1970, as amended from time to time.
 - iv) On contractors being declared insolvent by the competent Court of Law.
 - v) The contractor provides unsatisfactory services.
 34. During the notice period of termination of the contract in the contingencies contemplated

above, the contractor shall keep on discharging his duties as before till the expiry of notice period. It shall be the duty of the contractor to withdraw all the persons deployed by him on expiry/termination of the contract and will ensure that no person creates any disruption/hindrance or problems of whatsoever nature to TIFR.

35. Income Tax will be recovered from the contractor's monthly bill as per the Govt. of India's order and necessary TDS certificate will be issued to him as a proof of having deducted the Tax.
36. All disputes arising from this contract in respect of personnel posted at TIFR concerning their wages or any other matter connected with their service conditions under relevant Labor Laws are solely and wholly the responsibility of the Contractor. The TIFR will be Free from all encumbrances either from the Government or from any other sources.
37. TIFR Hyderabad GST NO is: 36AAATT3951F2ZG. GST rule will be applicable with effect from 01.07.2017 as per GST regime. The applicable TDS /other charges if any as per GST rule will be deducted.
38. The contractor should submit a valid GST Registration document / certificate etc. The TIFR will pay Goods and Services Tax (GST), as applicable on the bill submitted by the contractor.
39. That the contractor shall ensure that the persons so deployed do not allow any property of the TIFR to be taken out of the premises without a Gate Pass signed by the designated officials of the Institute. As a safeguard against any dishonesty, connivance and/or ulterior motive, the specimen signature of the officials designated and authorized to sign the gate pass will be intimated in writing to the contractor along with subsequent changes, if any. The Administrative Officer of TIFR shall take necessary steps to ensure compliance and necessary action in this respect.
40. **ARBITRATION**
In the event of any question, dispute/difference arising under the agreement or in connection herewith (except as to matters the decision of which is especially provided under this agreement) the same shall be referred to the sole arbitration to Centre Director TIFR, Hyderabad or his nominee. All suits arising out of the Annual Maintenance Contract and agreement, if any, shall be settled only in the Court of Law located in Hyderabad, Telangana state.

The award of the arbitrator shall be final and binding on their parties. In the event of such arbitrator to whom the matter is originally referred is being transferred or vacating his office or resigning or refusing to work or neglecting his work or being unable to act for any reason whatsoever, the TIFR shall appoint another person to act as arbitrator in place of the out-going arbitrator in accordance with the terms of this agreement and the persons so appointed shall be entitled to proceed with the reference from the stage at which it was left by his predecessor. The Arbitrator may give interim award(s) and/or directions, as may be required subject to the aforesaid provisions, the Arbitration & Conciliation Act, 1996 and the rules made thereunder and any modifications thereof from time to time being in force shall be deemed to apply to the arbitration proceedings under this clause.

SECTION-VII

SPECIAL CONDITIONS OF CONTRACT

1. Engagement terms of Staff::

- i. The agreement between TIFR-Hyderabad and the contractor shall be purely on the basis of service agreement. The Contractor shall make his own arrangements for the engagement of the labor.
- ii. In respect of the engagement, employment, wages, transport, paying, feeding, housing and working conditions of labor and of all matters connected therewith, the contractor shall be solely responsible and liable.
- iii. During the continuance of the Contract, the contractor shall at all times be liable to obligations imposed on him by the provisions and requirements of any Central or State Statute ordinance or other law or any Regulation or Bye-law of any local or other duly constituted authority which may be applicable including any such law regulation or order passed or made or coming into force during the period of the Contract.
- iv. The Contractor shall comply with the provision of all labor legislation including the requirements of:
 - a) The payment of Wages Act
 - b) Owner's Liability Act
 - c) Workmen's Compensation Act
 - d) Contractor Labour (Regulation & Abolition) Act 1970 and Central Rules 1971 Apprentices Act 1961
 - e) Any other Act or enactment relating thereto and rules framed there under from from time to time.
- v. The successful tenderer shall keep all mandatory records like PF, ESI, Bonus etc. of his employees deployed at TIFR, Survey No. 36/P, Gopanpally (Village), Serilingampally Mandal, RRDist, Hyderabad-500046 as per requirement of the labor enforcement inspector from time to time.
- vi. The successful tenderer shall take necessary license from the Asst. Labour Commissioner and comply with the central Labour Act of 1970.
- vii. The successful tenderer shall have to take necessary insurance coverage for his workmen and keep TIFR- Hyderabad indemnified against risk. Copy of such insurance premium receipt shall be submitted to TIFR-Hyderabad before the release of first payment.

- 2. Accidents:** The Contractor shall report within 24 hours of the occurrence of any accident or mishap at or about the Site or in connection with the execution of the work shall report such



incident to TIFR- Hyderabad. The Contractor shall also report such accidents to the competent authority whenever such report is required by law.

3. **Insurance:** Workman insurance policy in the joint name of TIFR- Hyderabad and the Bidder should be submitted to TIFR- Hyderabad before commencing the work. Contractors shall cover all the men and laborers deployed by him on this work under an adequate comprehensive contractor's all risk policy, to insure Workmen and third party insurance etc.
4. The work is to be carried out in occupied office and laboratory premises and hence the contract shall be governed by the rules of TIFR- Hyderabad regarding the working hours, supply & removal of materials etc. The contractor and their personnel shall not cause disturbance to the staff and research activities of TIFR- Hyderabad.
5. The contractor should make proper safety arrangements like safety belts and helmets, etc. for the persons working on site. Contractor shall provide an individual identity card to each of his staff /worker as per the approval format. The identity card shall be carried and displayed by the person during his entire presence or working in the premises.

Date:

(Name & signature of the contractor with office seal)



SECTION-VIII

APPENDIX TO FORM OF TENDER

a)	Minimum amount to third party insurance	The successful tenderer shall take "all risk policy" for the contract value and workmen compensation policy for the workers engaged in the work. The contractor shall indemnify the TIFR- TCIS for any loss or damage that occurs to persons or building or third party policy shall be minimum Rs. 2 lakh per party while executing the work. Third party liability in contractors all risk persons for any one accident or occurrence and 5.00 lakh in respect of damage to property for any one accident or occurrence. Note: These policies shall be valid till the completion of the work. If the contractor does not provide these policies, TIFR-TCIS reserves the right to take the above insurance policies themselves and recover the cost thereof from the bill of the contractor.
b)	Period of commencement	From 01.04.2024 to 31.03.2025
c)	Period of Contract	12 months
d)	EMD to be deposited	Rs.93,980/-
e)	Security Deposit	Demand Draft @ 5% of the work order value or Bank Guarantee of same value. EMD of successful tenderers will be adjusted against this money.



SECTION-IX

PRICE BID

PRICE BID

VOLUME-II

Annual Maintenance Contract for Operation & Maintenance of water supply, sewage system and carpentry works on 24x7 Basis on all days at TIFR, Survey No. 36/P, Gopanpally (Village), Serilingampally (Mandal), RR Dist., Hyderabad-500046.

NAME OF THE TENDERER: -----

ADDRESS: -----

Last date of submission of the tender: On or before 21.02.2024 by 13:00 Hrs.

PRICE BID

PART- I :Repairs/Alteration works
--

Sno	Description	Quantity	Unit	Rate(Rs)	Amount(Rs)
A	Plumbing material				
1	Stopper bush for Urinal pushcock Make:Jaguar/Hindware/Cera/Equivalent	6	Nos		
2	Springs for Urinal pushcock Make:Jaguar/Hindware/Cera/Equivalent	6	Nos		
3	Piston for Urinal pushcock Make:Jaguar/Hindware/Cera/Equivalent	3	Nos		
4	Springs for EWC push cock Make:Jaguar/Hindware/Cera/Equivalent	6	Nos		
5	Washer for EWC push cock Make:Jaguar/Hindware/Cera/Equivalent	5	Nos		
6	Washer for EWC Inlet Make:Jaguar/Hindware/Cera/Equivalent	10	Nos		
7	Seat covers for EWC Cat. No:CINTIA B1520102 Make:Cera/Hindware/Equivalent	10	Nos		
8	Silicon Tube, White color -280ml of any standard make	10	Nos		
9	Push cock filter Wash basin. Make:Jaguar/Hindware/Cera/Equivalent	10	Nos		
10	White cement - 5kg pack Make:Birla/JK white/Equivalent	4	pack		
11	PVC Trap seal 4" size Make: Ashirwad/sudhakar/equivalent	20	Nos		
12	TeflonTape	5	Box		



TATA INSTITUTE OF FUNDAMENTAL RESEARCH
(Autonomous Institution of the Department of Atomic Energy, Government of India)
Survey No.36/P, Gopanpally Village, Serilingampally Mandal, Ranga Reddy
District, Hyderabad-500046, Telangana

	Make:Ashirvad/Sudhakar/Equivalent				
13	CPVC ¾" pipe for hot water lines-SDR-11 Make:Ashirvad/Sudhakar/Equivalent	30	Mtr		
14	CPVC solvent-250ml Make:Ashirvad/Sudhakar/Equivalent	5	Tin		
15	Health faucet set for EWC's Cat No:- FB030105AB Make:-Cera/Jaguar/Hindware/Equivalent	15	Nos		
16	Inlet pipe for wash basin Make:Kohinoor/Equivalent	20	Nos		
17	Screws 2" size, Make: Jindal/Akshar/SLG/Equivalent	1	Box		
18	Screw plastic plug & wooden gattis, Make:Akshar/SLG/Equivalent	2	Box		
19	CPVC Pipe 3/4" size Make :Ashirwad/Astral/Equivalent	40	Mtr		
20	Pedestal WashBasin of size 57 cm x 48cm Model No:-10096 Studio Make:Hindware/Jaquar/Cera/Equivalent.	2	Nos		
21	CPVC MAPT 2"X2" Make:Ashirwad/Sudhakar/Astral/Equivalent	4	Nos		
22	CPVC Union 2" Make:Ashirwad/Sudhakar/Astral/Equivalent	2	Nos		
23	GI Gate valve 2" Make:L&T/Zoloto/Equivalent	2	Nos		
24	PPR FABT 3"X2" Make:-Astral/ Equivalent	2	Nos		
25	PPR MABT 3"X2" Make: Astral/ Equivalent	2	Nos		
26	CPVC MABT-1" Make-Ashirvad/sudhakar/Astral/Equivalent	2	Nos		
27	Brass NRV Valve -1 ¼"	1	Nos		

	Make: Zoloto/Equivalent				
28	Brass NRV Valve -2" Make: Zoloto/Equivalent	1	Nos		
29	Brass Ball cock-2" Make:Ashirvad/sudhakar/Astral/Equivalent	1	Nos		
30	Bucket Strainer gasket	3	Nos		
31	Brass Foot valve-2" Make:Ashirvad/Astral/sudhakar	1	Nos		
32	Exhaust fan Belts (A43)	4	Nos		
33	Rotor Chain 20 mm Pitch Make:Rolcon Engineering / Equivalent	2	Mtr		
34	Rotor chain Clips 20mm Pitch Make:Rolcon Engineering / Equivalent	10	Nos		
35	Cartridge filters-20" Make: ion exchange/Alfa/Equivalent	10	Nos		
36	Indion8111s antiscalant, Make:Ion Exchange/Equivalent	30	kg		
37	Alkali chemical-5 liter, Make: Good chemistry/HM/Equivalent	1	Tin		
38	Acidic chemical- 5ltr, Make:Good chemistry/HM/Equivalent	1	Tin		
39	TDS meter of any approved standard make	1	Nos		
40	Sodium hypochlorite(Commercial grade of 10-12% strength) of any standard make	500	Kg		
B	Carpentry material				
41	Door closers Heavy duty(60kgs) model:DC60SM of make Dorset/Godrej/Hardwin/ Equivalent	15	Nos		
42	Door stoppers in stainless steel-6" size, Make:Hardwin/Godrej/Dorset/ Equivalent	20	Nos		



43	Door Handles cylindrical type-10" Make:Hardwin/Godrej/Dorset/ Equivalent	4	Nos		
44	Mortise locks with lever handle Make:Hardwin/Godrej/Dorset/ Equivalent	10	Nos		
45	Stainless steel Screws -2" Make: Jindal/Akshar/SLG/Equivalent	2	Box		
46	Door Hinges-4" in stainless steel Make:Hardwin/Godrej/Dorset/ Equivalent	10	Nos		
47	Aluminium Tower bolts 8" long make: Hardwin/Godrej/Dorset/ Equivalent	6	Nos		
48	Door Floor Springs- Model:FS150 Silver Satin of make:Dorset/Hardwin/Godrej/ Equivalent	6	Nos		
	Sub Total (Sno.1 to 48)				
	Add GST@18%				
	Total of PART-I				
PART-II :STP Site visit and water testing charges					
1	Charges for testing of input and output water of Sewerage Treatment Plant (STP) in a approved/qualified lab and certified by qualified engineer/ consultant(Once in a month)	12	Months		
2	Site visit of expert(must be of B.Tech, Environmental Engg / MTech,Environmental Engg) to verify the health condition of STP (Sewerage Treatment Plant)(Once in a month)	12	Months		
	Sub Total (Sno.1 to 2)				
	Add GST@18%				
	Total of PART-II				



Part-III: Operation & Maintenance contract					
Sl no	Description	Qty	Unit	Rate per month	Amount
1	Engage of Highly skilled supervisor @ 1person daily in a month	1	Each	31813.57	31,813.57
2	Engage of Skilled category plumbers @ 6 persons daily in a month	6	Each	29548.51	1,77,291.06
3	Engage of Skilled category Carpenter @ 1 person daily in a month	1	Each	29548.51	29,548.51
4	Engage of Unskilled category helper @ 1 person daily in a month	1	Each	24676.31	24,676.31
5	Subtotal (Sno.1 to 4) above (Total monthly minimum wages)				2,63,329.45
6	Total Yearly minimum wages (S.no 5 x 12 months)				31,59,953.40
7	Service Charges @of Sno.6 above				
8	Sub Total of (Sno.6 & Sno.7)				
9	Add GST @18% on Sr No. 8				
10	Total of PART-III (Sno8 + Sno.9)				
IV	Grand total of contract (Total of PART- (I + II + III) above				
	Rupees in words:only				



NOTE:

- a. The contractor shall provide minimum one-day duty off once in a week for the employees working in shifts and shall provide relievers for the employees on off duty / sick / leave. However, in case of exigencies, the contractor shall provide services beyond the above mentioned hours.
- b. The TIFR- Hyderabad shall not permit double shift for any staff employed by the contractor.
- c. The quoted rates shall be inclusive of Minimum Wages payable as per Central Labour commission for the classification of skill set of manpower engaged, all taxes, duties, insurance, works contract tax, sales tax, VAT etc. all inclusive.
- d. The contractor shall make the payment to personnel engaged by him as per minimum wages notified by Office of the Regional Labour Commissioner (Central) and any revision in the wages during the period of contract.
- e. The quoted rates shall be inclusive of all applicable statutory payments viz. Minimum Wages(**including revisions**), PF, ESI, Gratuity, Bonus and necessary risk policy for covering the comprehensive risk of all employees etc.
- f. Conditional tenders shall be summarily rejected.
- g. Please note that the final **bid amount** will be considered for evaluation of tenders.
- h. Contractor shall take care of any probable revision in minimum wages during the contract period and no additional payments will be made in this regard.
- i. The contractors are advised to visit the site and thoroughly understand the nature and scope of work and be familiar with the site conditions before quoting.
- j. I/We have examined the scope of work and terms & conditions of the tender for the said works. If this tender is accepted by TIFR- Hyderabad, I/We hereby agree to execute the works in accordance with terms and conditions of the tender.

Date:

(Signature and Name of the authorized person
of the firm/contractor with office seal)